

# **Yellow Pine Solar Plan of Development**

Prepared for

**Yellow Pine Solar, LLC**

Prepared by

**SWCA Environmental Consultants**

June 2016



# YELLOW PINE SOLAR PLAN OF DEVELOPMENT

Prepared for

**Yellow Pine Solar, LLC**  
700 Universe Boulevard  
Juno Beach, Florida 33408  
Attn: Jesse Marshall  
(561) 691-7171

Prepared by

**SWCA Environmental Consultants**  
7210 Placid Street  
Las Vegas, Nevada 89119  
(702) 248-3880  
[www.swca.com](http://www.swca.com)

SWCA Project No. 37332

June 2016



# CONTENTS

<b>1.0 PROJECT DESCRIPTION.....</b>	<b>1</b>
1.1 Introduction.....	1
1.1.1 Applicant’s Schedule for Project, Including Anticipated Timelines for Permitting, Construction and Operation, and Any Phased Development, As Appropriate.....	3
1.2 Proponent’s Purpose and Need for the Project .....	3
1.3 General Facility Description, Design, and Operation .....	4
1.3.1 Project Location, Land Ownership, and Jurisdiction.....	4
1.3.2 Legal Land Description of Facility (Federal and Non-Federal Lands).....	6
1.3.3 Facility Location and Components .....	8
1.3.4 Temporary Construction Workspace, Yards, Staging Areas .....	12
1.3.5 Erosion Control and Stormwater Drainage.....	13
1.3.6 Vegetation Treatment and Weed Management.....	13
1.3.7 Health and Safety Program .....	13
1.4 Alternatives Considered by Applicant .....	13
1.5 Other Federal, State, and Local Agency Permit Requirements .....	13
1.6 Financial and Technical Capability of Applicant .....	16
<b>2.0 CONSTRUCTION OF FACILITIES.....</b>	<b>16</b>
2.1 Construction Process and Schedule .....	16
2.1.1 Construction Process and Schedule .....	16
2.1.2 Construction and Operations Transportation Needs .....	18
2.1.3 Civil Works Description .....	18
2.1.4 Generation Tie-Line Construction Sequence.....	20
<b>3.0 RELATED FACILITIES AND SYSTEMS .....</b>	<b>22</b>
3.1 Transmission System Interconnect.....	22
3.1.1 Existing and Proposed Transmission System .....	22
3.1.2 Ancillary Facilities and Substations.....	22
3.1.3 Status of Power Purchase Agreements .....	22
3.1.4 Status of Interconnect Agreement.....	22
3.1.5 General Design and Construction Standards .....	23
3.2 Other Related Systems.....	23
3.2.1 Communications System Requirements (Microwave, Fiber Optics, Hard Wire, Wireless) During Construction and Operation.....	23
<b>4.0 OPERATIONS AND MAINTENANCE .....</b>	<b>23</b>
4.1 Operations Staff and Vehicles .....	23
4.2 Operation and Maintenance Activities.....	23
4.3 Water Use and Waste Management.....	24
4.3.1 Water Use .....	24
4.3.2 Water Treatment .....	25
4.4 Waste Management.....	25
4.4.1 Hazardous Chemicals .....	25
4.4.2 Wastewater.....	25
4.4.3 Solid and Non-Hazardous Waste .....	26
4.4.4 Hazardous Solid and Liquid Wastes .....	26

4.5 Termination and Reclamation.....	26
<b>5.0 ENVIRONMENTAL CONSIDERATIONS AND OTHER RESOURCES.....</b>	<b>27</b>
5.1 General Vegetation .....	27
5.2 General Wildlife .....	27
5.3 Threatened and Endangered Species.....	28
5.4 Wetlands and Jurisdictional Waters.....	28
5.5 Air Quality .....	28
5.6 Visual Resources.....	29
5.7 Surface and Groundwater Quality and Quantity.....	29
5.8 Control or Structural Change on Any Stream or Other Body of Water.....	29
5.9 Existing Noise Levels .....	29
5.10 Soil and Soil Stability.....	30
5.11 Cultural Resources.....	30
<b>6.0 LITERATURE CITED.....</b>	<b>31</b>

## Appendices

- Appendix A. Preliminary Single-Axis Array Layout Design
- Appendix B. Typical Pole Structures for Gen-tie

## Figures

<b>Figure 1.</b> Yellow Pine Solar Project location.....	2
<b>Figure 2.</b> Yellow Pine Solar Project Application Area.....	5
<b>Figure 3.</b> Illustration of transmission line conductor stringing.....	21

## Tables

<b>Table 1.</b> Application Area and Gen-Tie Alignment Aliquot Parts.....	6
<b>Table 2.</b> Summary of Permits Required or Potentially Required.....	14
<b>Table 3.</b> Preliminary Construction Schedule.....	17
<b>Table 4.</b> YPSP Construction Plan.....	18

## 1.0 PROJECT DESCRIPTION

### 1.1 Introduction

On October 21, 2011, Boulevard Associates, LLC, a subsidiary of NextEra Energy Resources, LLC (NextEra), filed an application for a right-of-way (ROW) grant (N-090788) with the Southern Nevada District Office of the Bureau of Land Management (BLM) for the Sandy Valley Solar Project on 3,272 acres of land (Figure 1). The Sandy Valley Solar Project has not been built to date; however, the application was filed prior to the BLM's Final Solar Programmatic Environmental Impact Statement (Final Solar PEIS; BLM and U.S. Department of Energy [DOE] 2012) and as a pending solar application at the time of this publication, the project is not subject to the decisions adopted by the *Record of Decision (ROD) for Solar Energy Development in Six Southwestern States* (BLM 2012).

On June 24, 2016, an amended application was submitted by Yellow Pine Solar, LLC (Applicant), a subsidiary of NextEra, with a new project name, the Yellow Pine Solar Project (YPSP or Project). The Applicant is proposing to develop the YPSP in order to construct, operate, and maintain an efficient, economic, reliable, safe, and environmentally sound solar-powered generating facility. The YPSP would be in Clark County, Nevada, completely on land managed by the BLM (see Figure 1). Based on preliminary discussions with the BLM and initial evaluation of resource concerns, areas to the northwest of the original application area are being included to provide more flexibility for conflict avoidance. The Applicant has amended its original ROW application to include a larger amended Application Area (herein called Application Area) of 9,290 acres. Within the Application Area, a Project Area no more than 3,000 acres would be constructed. The exact siting of the Project Area has not been finalized and will be designed to avoid resource concerns where applicable.

The Application Area encompasses the original application area as well as lands proposed as variance areas, as described in the Final Solar PEIS (BLM and DOE 2012). Appendix B, Section B1.2 of the Final Solar PEIS Record of Decision (ROD) states that amendments to pending applications are not subject to the decisions of the ROD if they “are related to avoiding resource or land use conflicts, adapting the project to third-party-owned infrastructure constraints, or using or designating translocation or mitigation lands” (BLM 2012).

The YPSP would be an approximately 250-megawatt (MW) photovoltaic (PV) power plant that would provide renewable energy to Nevada's electrical transmission grid at the Sandy Valley Substation via construction of a new transmission line (Gen-tie Alternative 1), or by looping into the existing Valley Electric Association (VEA) 230-kilovolt (kV) transmission line (Gen-tie Alternative 2). The plant would generate electricity using multiple arrays of PV panels electrically connected to associated power inverter units. The current from the power inverters would be gathered by an internal electrical collection system and transformed to transmission voltage prior to leaving the Project Area. PV panels generate electricity using the photoelectric effect, whereby the materials in the panels absorb sunlight's energy in the form of photons and release electrons. The capture of these free electrons produces an electrical current, which can be collected and supplied to the electrical power grid.

For a 250-MW solar project, it is estimated that up to 9 acres per MW would be needed to construct the facility, which computes to 2,250 acres. Accounting for room to avoid resource conflicts, the Applicant plans to construct the YPSP facility on a Project Area of no more than 3,000 acres inside the 9,290-acre Application Area.

This Plan of Development (POD) is being submitted to the BLM by Yellow Pine Solar, LLC, to support its existing ROW application and has been compiled with currently available information. This document is subject to change and will be modified as the Project undergoes final engineering and design.

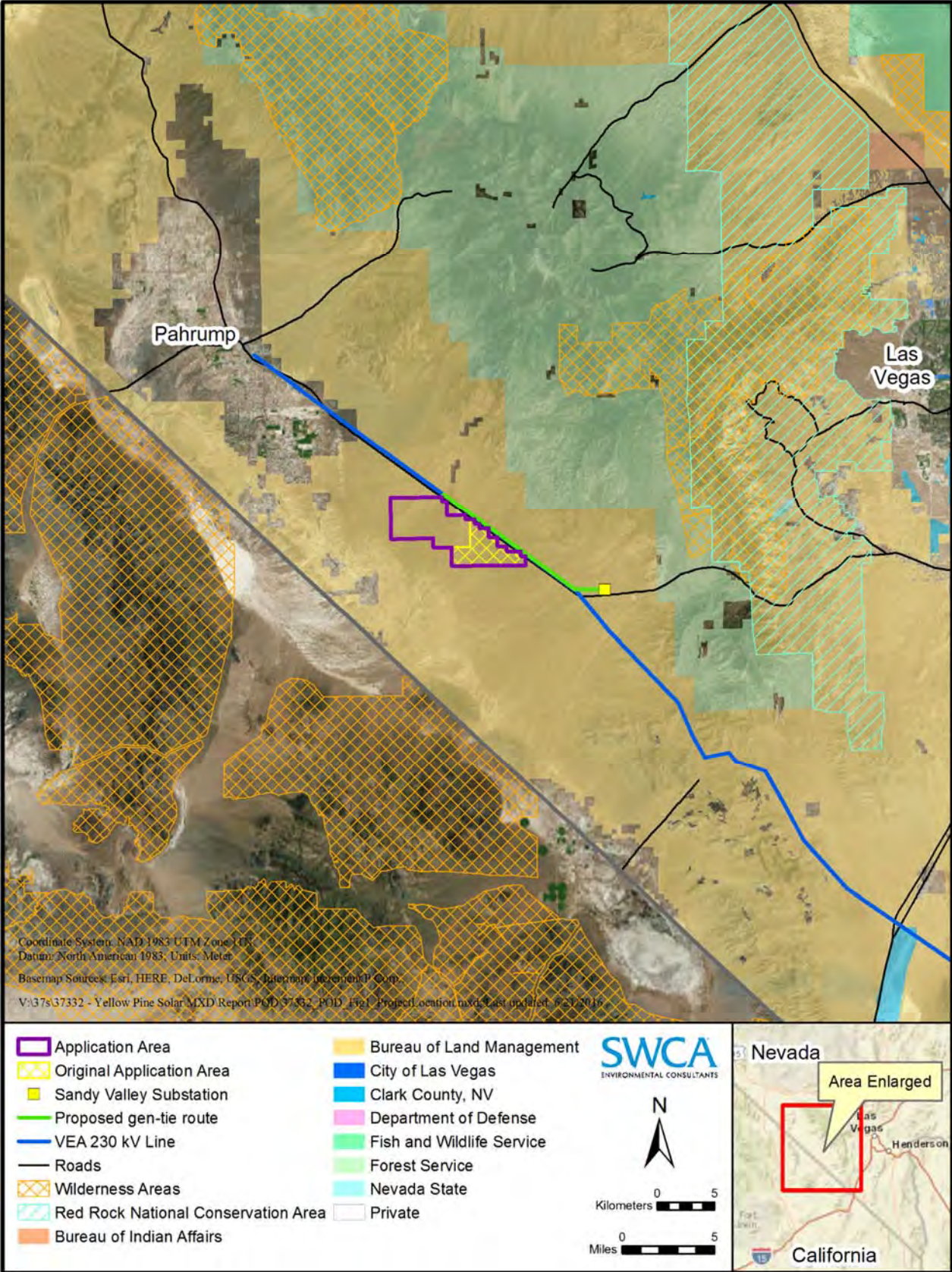

**Figure 1.** Yellow Pine Solar Project location.



### **1.1.1 Applicant's Schedule for Project, Including Anticipated Timelines for Permitting, Construction and Operation, and Any Phased Development, As Appropriate**

The Applicant expects the permitting process for the YPSP to take 18 to 24 months. Based on that timeline, construction is anticipated to begin in the third quarter of 2019, and to continue for up to 18 months. The Applicant plans to complete the appropriate National Environmental Policy Act (NEPA) documentation by the middle of 2019. By the third quarter of 2019, the Applicant anticipates receiving a ROW grant from BLM. Following submittal of a subsequent version of this POD suitable for construction and its acceptance by BLM, the Applicant proposes to begin an approximate 18-month construction schedule. The Applicant anticipates commencing full commercial operations by the end of 2020.

## **1.2 Proponent's Purpose and Need for the Project**

The State of Nevada has recognized the need for new and diverse energy resources, including renewable energy generation options. The Nevada Renewable Portfolio Standard (RPS) (Nevada Revised Statutes [NRS] 704.7821) was revised on July 1, 2009, by Senate Bill 358 to state that by calendar year 2025, no less than 25% of the total amount of electricity sold by NV Energy to its retail customers in Nevada must be from renewable energy resources. Additionally, a solar "carve-out" has been included which states that beginning in 2016, at least 6% of the energy should be from solar. NV Energy is expecting to acquire renewable energy from multiple generating facilities to meet, at a minimum, the mandated RPS target of 20% of retail sales coming from renewable resources in 2015–2019, 22% in 2020–2024, and 25% in 2025.

In addition, California's Renewable Energy Portfolio Standard mandates that 25% of retail sales must come from renewable (green) energy by 2016, and 33% by the end of 2020. In October 2015, Senate Bill 350 was passed and requires retail sellers and publicly owned utilities to procure 50% of their electricity from renewable energy by 2030. Such aggressive goals, coupled with the California's projected energy demand growth, dictate that large-scale renewable generation projects are of utmost importance for state regulators, utilities, and citizens alike.

The YPSP is being developed to supply renewable electric energy (as an alternative to new fossil fuel generation resources) to serve the electrical load requirements in Nevada, California, and the southwest United States. Applicant's specific objectives for the YPSP are the following:

- to construct, operate, and maintain an efficient, economic, reliable, safe, and environmentally sound utility-scale solar-powered generating facility that will meet the requirements for the long-term wholesale purchase of renewable electric energy for distribution to utility customers
- to develop a site with a proven solar resource
- to develop a site in close proximity to transmission infrastructure in order to minimize environmental impacts

The costs of construction, operation, and maintenance are dependent on a number of factors and will vary depending on the final design and project configuration. Potential public benefits of the proposed YPSP include, but are not limited to, increased energy-generating capacity to meet market demands, low carbon footprint energy source, use of a valuable renewable energy source, and local construction and operations job creation.

## **1.3 General Facility Description, Design, and Operation**

The following sections describe the solar field(s), power blocks, major equipment, switchyard, ancillary systems, evaporative ponds, site stormwater management/drainage, buildings, and other structures needed to develop a 250-MW facility within the Project Area. The YPSP will be designed, constructed, and operated in accordance with current and future applicable laws, ordinances, regulations, and standards. Preliminary panel design lay-out drawings for possible sites within the Application Area are included in Appendix A.

### ***1.3.1 Project Location, Land Ownership, and Jurisdiction***

The Application Area is located approximately 10 miles southeast of Pahrump, Nevada, and approximately 32 miles west of Las Vegas, Nevada. The Application Area is situated in Pahrump Valley and surrounds the intersection of Nevada State Route (SR) 160 and Tecopa Road (Figure 2). The YPSP facilities will be located entirely on lands administered by the BLM. At the request of the BLM, the Applicant is currently looking at different locations within the Application Area for development of the YPSP, to avoid resource conflicts.

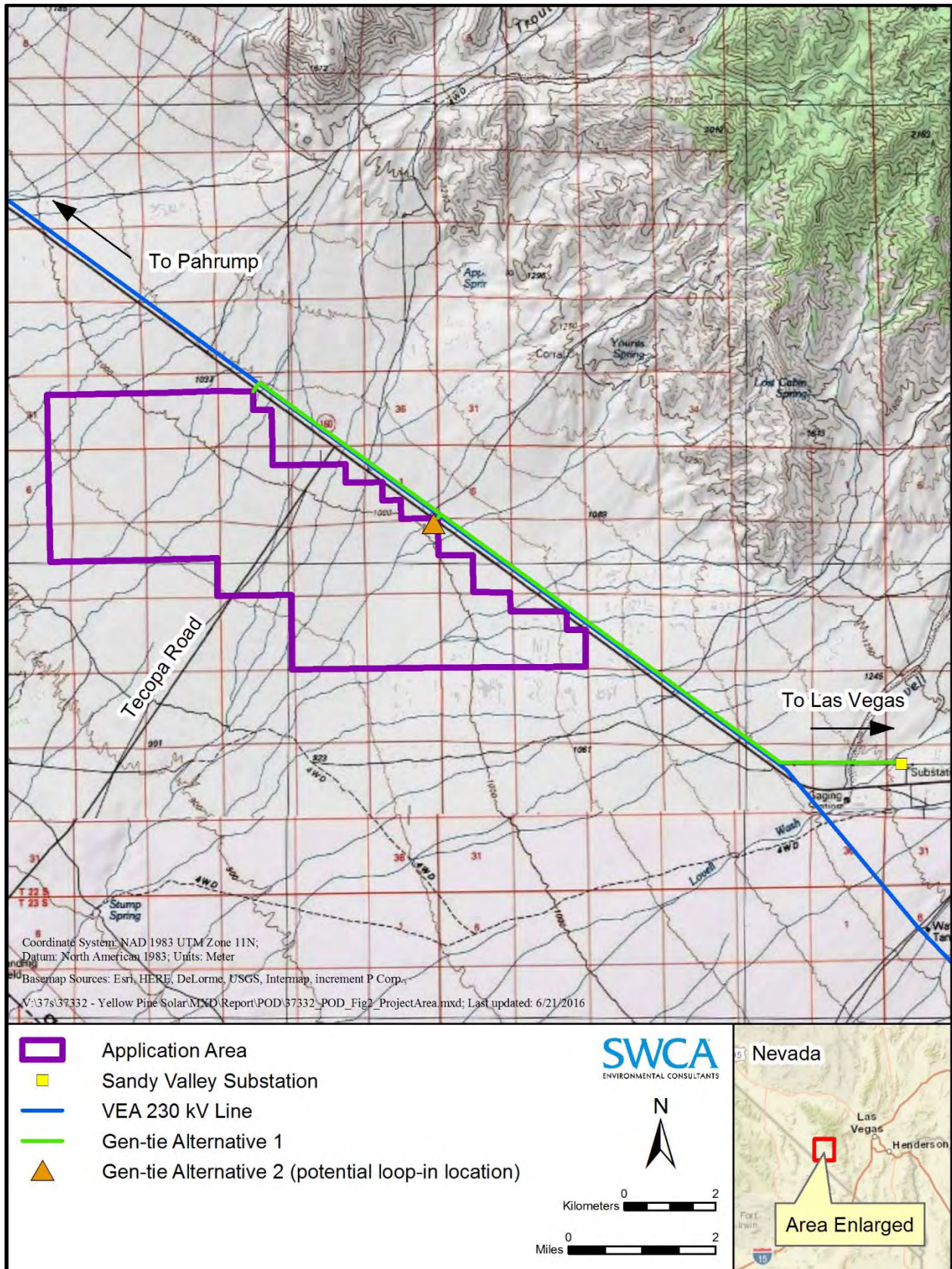

Figure 2. Yellow Pine Solar Project Application Area.

### 1.3.2 Legal Land Description of Facility (Federal and Non-Federal Lands)

The Application Area is located in portions of Township 22 South, Range 55 East; portions of Township 22 South, Range 56 East; and portions of Township 21 South, Range 55 East. Table 1 lists the BLM lands requested to the quarter quarter-section as identified in the filed ROW grant application.

**Table 1.** Application Area and Gen-Tie Alignment Aliquot Parts

Meridian	Township	Range	Section	Subdivision
<i>Application Area</i>				
MDM 21	21 South	55 East	31	SE1/4 of NE1/4
			31	E1/2 of SE1/4
			32	S1/2
			32	S1/2 of N1/2
			33	S1/2
			33	S1/2 of N1/2
			34	SW1/4
			34	S1/2 of NW1/4
			34	W1/2 of SE1/4
			MDM 21	22 South
1	NW1/4 of SW1/4			
2	S1/2			
2	S1/2 of NW1/4			
2	SW1/4 of NE1/4			
3	W1/2			
3	SE1/4			
3	W1/2 of NE1/4			
3	SE1/4 of NE1/4			
4	All			
5	All			
6	E1/2 of E1/2			
7	E1/2 of NE1/4			
8	N1/2			
9	N1/2			
MDM 21	22 South	56 East	7	SW1/4
			17	S1/2
			17	S1/2 of NW1/4

**Table 1.** Application Area and Gen-Tie Alignment Aliquot Parts, Continued

<b>Meridian</b>	<b>Township</b>	<b>Range</b>	<b>Section</b>	<b>Subdivision</b>
<i>Application Area, Continued</i>				
MDM 21	22 South	56 East	17	SW1/4 of NE1/4
			18	All
<i>Gen-tie Alignment</i>				
MDM 21	21 South	55 East	34	NE1/4
			34	E1/2 of NW1/4
			35	SW1/4
			35	SW1/4 of NW1/4
			35	S1/2 of SE1/4
			35	NW1/4 of SE1/4
MDM21	22 South	55 East	1	W1/2 of NW1/4
			1	SE1/4 of NW1/4
			1	NE1/4 of SW1/4
			1	SE1/4
			2	N1/2 of NE1/4
MDM21	22 South	56 East	6	SW1/4 of SW1/4
			7	N1/2 of NW1/4
			7	SE1/4 of NW1/4
			7	W1/2 of NE1/4
			7	SE1/4 of NW1/4
			7	N1/2 of SE1/4
			8	SW1/4
			8	SW1/4 of SE1/4
			17	N1/2 of NE1/4
			17	SE1/4 of NW1/4
			17	NE1/4 of NW 1/4
			16	SW1/4 of NW1/4
			16	N1/2 of SW1/4
			16	S1/2 of SE1/4
			16	SE1/4 of SW1/4
			16	NW1/4 of SE1/4
			21	NE1/4 of NE1/4
			22	NW1/4
			22	SW1/4 of NE1/4
			22	NE1/4 of SW1/4
			22	N1/2 of SE1/4
			22	SE1/4 of SE1/4
			23	S1/2 of SW1/4
			26	N1/2 of NW1/4

**Table 1.** Application Area and Gen-Tie Alignment Aliquot Parts, Continued

Meridian	Township	Range	Section	Subdivision
<i>Gen-tie Alignment, Continued</i>				
MDM21	22 South	56 East	26	NE1/4
			26	SE1/4 of NW1/4
			25	N1/2
MDM 21	22 South	57 East	30	NW1/4

### 1.3.3 Facility Location and Components

The Application Area (see Figure 2) is located mainly to the west and south of the intersection of SR 160 and Tecopa Road, which is southeast of Pahrump, Nevada. The YPSP facilities would be located entirely on BLM-administered lands and would encompass approximately 3,000 acres within the Application Area in Clark County, Nevada. All road improvements and any needed generation tie line (gen-tie) would also be located on BLM land within the overall Application Area. The total road improvements for the main access road are currently unknown although it is anticipated the main access would connect to SR 160 to the north.

Two interconnection alternatives are currently being considered. Gen-tie Alternative 1 would consist of construction of a gen-tie that would cross SR 160 and the existing nearby VEA 230-kV transmission line, and then parallel the line southeast to the VEA-owned Sandy Valley Substation. The total length of the 138-kV gen-tie line that would be constructed for Gen-tie Alternative 1 would depend on final design and would be between approximately 7 and 11 miles in length, depending on the final Project Area location. Gen-Tie Alternative 2 consists of constructing a substation within the Project Area that would provide an interconnection point to loop in to the existing VEA 230-kV transmission line that parallels SR 160. This alternative would only require the construction of a short gen-tie line. In either case, a gen-tie line or loop-in line would cross SR 160, and therefore a road crossing through a Nevada Department of Transportation (NDOT) ROW will be needed.

The YPSP would consist of two major types of facilities: PV solar arrays (the main YPSP footprint) and linear facilities. Each of these components is explained in detail in the following sections.

A number of linear facilities would be developed externally from the main power plant footprint. These linear facilities may include:

- Main access roads
- A 138-kV (Gen-tie Alternative 1) or 230-kV (Gen-tie Alternative 1) gen-tie line to carry electricity to one of the proposed points of interconnection
- Distribution power for buildings and backup for control systems
- Communications cables or lines

The PV panel array facilities would be located on approximately 3,000 acres in the Project Area. The entire power plant facility footprint would be enclosed by fences.

The YPSP facilities would include the following major components or systems:

- PV modules/arrays
- Solar trackers or fixed support structures



- Direct current (DC) collection cable and combiner boxes
- Solar power inverters and pad-mount transformers
- Electrical collection system (34.5-kV lines)
- Main step-up transformer/on-site substation
- 138-kV main step-up transformer and generation tie-line (Gen-tie Alternative 1) or 230-kV main step-up transformer and substation for loop-in to existing VEA 230-kV transmission line (Gen-tie Alternative 2)
- Administration/operation and maintenance (O&M) building and local warehouses

## **PV MODULES / ARRAYS**

The YPSP will utilize state-of-the-art PV technology in which the sun’s light energy is converted directly into DC electrical energy within the PV panels, referred to as “modules.” The PV modules can be mounted together in different configurations, depending on the equipment selected, on a common support framework.

The modules are grouped together in solar arrays. The size of the array is based on the capacity of the equipment selected and is intended to generate the desired overall voltage and current output. Based on the current conceptual design, each solar array is intended to produce a net power output of approximately 2 MW (as alternating current [AC]) as described in the following section, “Electrical Collection System.” The overall capacity of the conceptual YPSP design (250-MW AC) is achieved with sufficient AC arrays to deliver 250 MW at the point of delivery. Solar energy technologies continue to evolve at a rapid rate and as a result, the exact arrangement and nature of the PV systems will be determined during the final design and appropriate updates will be made to this POD prior to construction.

## **SOLAR TRACKERS AND/OR FIXED SUPPORT STRUCTURES**

There are different types of mounting structures for the modules, depending on whether the modules will be fixed in one position or intended to track the sun’s motion during the day. A solar tracking mechanism is used to maximize the solar energy conversion efficiency by keeping the modules perpendicular to the sun’s energy rays throughout the day. This completed assembly of PV modules mounted on a framework structure is called a “tracker” as it tracks the sun from east to west. The PV module rows will be oriented north-to-south based on the mounting structure design; however, exact module support structure types will be determined during the final design. The single-axis tracker configuration is more complicated and is discussed in more detail below. A fixed support structure is also possible. In this application, the fixed structure would orient the panels in a permanent position towards the south at a certain angle to optimize production throughout the year without any mechanical movement or drive motors.

At this time, there are two types of tracker systems that may be selected for the YPSP: a ganged system or a stand-alone tracker system. A ganged tracker system uses one actuator to control multiple rows of PV modules through a series of mechanical linkages and/or gearboxes. A stand-alone system utilizes a single actuator for each row of PV modules. The exact tracker manufacturer and model will be determined in the final design. All trackers are intended to function identically in terms of following the motion of the sun.

Module layout and spacing is optimized to balance energy production versus peak capacity and will depend on the sun angles and shading caused by the horizon surrounding the YPSP. The spacing between the rows of trackers is dependent on site-specific features and tracker selection and will be identified in the final design, but in the current configuration, this spacing is approximately 16.5 feet between rows (post to post), which allows 12 feet of clearance for maintenance vehicles and panel access.

## **ELECTRICAL COLLECTION SYSTEM**

PV modules generate a low-voltage DC electrical output that is not suitable for direct connection to the AC utility grid used in the United States. The electrical collection system will be designed to convert the output power from the PV modules from DC to AC and then transform the power from low voltage to transmission-level voltage for connection to the grid, and to supply auxiliary power to the tracker systems. The DC output from the PV arrays will be transmitted to inverters through a combination of aboveground and underground DC electrical cables. As currently configured, the YPSP will use about 150 power inverter packages to accomplish the DC-to-AC power conversion process. The number of modules connected to each inverter is dependent on the specific model of modules, inverters and their capacities, which will be selected in the final design. In order to allow for greater electrical production in off-peak hours and an overall increase in power production, the DC quantity will exceed the AC plant rating in the range of 25%–40%. The resulting AC current from each individual inverter package will then be routed through underground or overhead AC cables to the corresponding medium-voltage, step-up transformer. Based on the preliminary design, the output voltage from each inverter will be increased to the desired substation feed voltage (34.5 kV) by these step-up transformers.

## **STEP-UP TRANSFORMATION / ON-SITE SUBSTATION**

The AC current will leave the step-up transformers via underground 34.5-kV lateral lines that may be routed into overhead electrical feeder lines. The feeder lines will be supported by multiple circuit 34.5-kV poles and will dead-end at the YPSP substation. The YPSP substation will occupy approximately 1 to 4 acres within the Project Area. The YPSP substation will consist of parallel sets of internal power distribution systems, (i.e., 34.5-kV buses and circuit breakers, disconnect switches, and main step-up transformer) to increase the voltage to the 230-kV transmission line voltage. The power from the combined solar arrays will be transformed from the medium-distribution voltage (34.5 kV) to the 138-kV substation voltage (Gen-tie Alternative 1) or to the 230-kV transmission line voltage (Gen-tie Alternative 2). The substation and interconnections will be built for 138 kV or 230 kV depending on the gen-tie alternative selected, and will operate at that nominal voltage.

## **INTERCONNECTION TO THE SANDY VALLEY SUBSTATION / VEA 230-KV LINE**

If Gen-tie Alternative 1 is utilized, the electrical power from the YPSP substation would be transmitted through a 7- to 11-mile gen-tie line for delivery at the Sandy Valley Substation located to the southeast of the Application Area. The Gen-Tie Alternative 1 alignment would be routed in a generally southeastern direction and would utilize an existing utility corridor along SR 160. The gen-tie would be constructed for the nominal operating voltage of the regional transmission system, which is 138 kV. The conductor wires will be supported by several different types of structures depending on exact routing. If the gen-tie crosses under an existing line it will utilize an “H-frame” structure approximately 90 to 120 feet tall (see Appendix B for pole structures) with a nominal span length of 1,000 feet and monopole structures (see Appendix B). These intervals may vary to accommodate site-specific engineering requirements. The gen-tie would consist of structures including tangent, angle, dead-end, and pull-off structures. The maximum height of supporting structures would be 120 feet. The typical height of the supporting structures would be 90 feet. Final hardware design would be determined during final engineering of the gen-tie.

The interconnection to the Sandy Valley Substation may or may not require the addition and modification of equipment in the substation, depending on requirements of the system operator which would be finalized after the interconnection agreement is determined. All work would be performed in accordance with the applicable electric utility standards. Expansion of the substation footprint would not be required as a result of YPSP’s interconnection.



Under Gen-tie Alternative 2, the YPSP would interconnect with the grid using an on-site substation that loops into the existing nearby VEA 230-kV transmission line. This substation would consist of structure, breakers, and controls that allow for transmission of power to occur with and without the solar project interconnected. In addition, the substation would include main step-up transformers, HV electrical controls, combining switchgear, and related structures that would be in place regardless of which gen-tie option is selected.

### **ADMINISTRATION BUILDING, CONTROL ROOM, AND WAREHOUSE LOCATIONS**

The YPSP will include an O&M facility, housed in an approximately 3,500-square foot building. The O&M building will be located near the YPSP access road. The O&M building will be a pre-engineered metal building with metal siding and roof. The building will provide a small administrative area, a work area for performing minor repairs and a storage (or warehouse) area for spare parts, transformer oil, and other incidental chemicals. The building will be supported on reinforced concrete mat foundations or individual spread footings. The floor will consist of a reinforced concrete slab. The administration area will be air conditioned and include offices, break room, rest rooms, and locker rooms with showers. The design and construction of the administration building and warehouse would be consistent with all applicable state and local building codes.

### **ROADS AND ACCESS**

Regional access to the facility would be from SR 160 via an access road from the north. This all-weather improved road would have one lane in each direction, with an approximately 16- to 24-foot width. The road would be sized to handle all potential vehicle traffic during construction and would be closed to public access. Auxiliary roads inside the facility footprint would be 16–24 feet wide and use compacted native materials or gravel surface.

Only a small portion of the overall plant site would be paved, primarily the YPSP access road and areas around the O&M building and plant substation. The remaining portions of the Project Area would remain unpaved. The entire site would be fenced appropriately to restrict public access during construction and operations. Chain-link security fencing would be installed around the site perimeter, substation, and other areas requiring controlled access. The security fence would be approximately 7–8 feet tall, including approximately 1 foot of barbed wire (three strands) mounted on 45-degree extension arms. The fence posts would be set in concrete or driven into the ground.

Controlled access gates would be located at the entrance to the facility. Site gates would be swing- or rolling-type access gates. Access through the main gate would require an electronic swipe card to prevent unaccompanied visitors from accessing the facility. All facility personnel, contractors, agency personnel, and visitors would be logged in and out of the facility at the main office during normal business hours. Visitors and non-YPSP employees (except agency personnel on government business) would be allowed entry only with approval from a staff member at the facility. Additional security may be provided through the use of closed circuit video surveillance cameras and anti-intrusion systems as required for protection of the power production facility.

### **PLANT AUXILIARY SYSTEMS**

The following plant auxiliary systems would control, protect, and support the YPSP and its operation.

**Lighting System.** Permanent outdoor night lighting will be provided at the O&M building, and the YPSP substation, although some portable lighting may be required for some maintenance activities that must be performed at night. Lighting will be kept to the minimum required for safety and security. Sensors, switches, and timers will be used to keep lighting turned off when not required and all lights will be

hooded and directed to minimize backscatter and off-site light. Lighting would be fixed to buildings and other structural supports where possible, or affixed to ground-mounted poles of approximately 15 to 20 feet height.

**Fire Protection.** Regular YPSP operations typically have a low risk of introducing fires because the majority of the materials within the solar arrays are non-combustible (aluminum, steel, or glass).

During construction activities a water truck or other portable trailer-mounted water tank will be kept on-site and available to workers for use in extinguishing small human-made fires. All vehicles working on-site will also carry a portable fire extinguisher.

The fire protection systems for the solar plant site operations may include a fire protection water system for protection of the O&M building, portable water tanks (Buffalos), and portable fire extinguishers. The YPSP's fire protection water system may be supplied from a water storage tank located on the solar plant site near the main entrance.

Additional emergency response would be provided externally by local municipalities, if required. The proponent would develop an escape fire plan in consultation with the BLM. This plan would be approved by the BLM and become a part of the authorization for the solar plant facility.

#### **1.3.4 Temporary Construction Workspace, Yards, Staging Areas**

A temporary staging area will be established on the solar facility site, including fenced parking, covered trash disposal facilities, construction trailers, a laydown area, and sufficient portable toilets and potable water for the construction staff. Mobile trailers or similar suitable facilities (e.g., modular offices) will be used as construction offices for YPSP and subcontractor personnel. Construction laydown and parking areas will be within the areas of the Project Area. During construction, temporary utilities will be provided for the construction offices, laydown area, and Project Area. Temporary construction power before the construction of permanent distribution power will either be provided by VEA or come from temporary diesel generators. Temporary area lighting will be provided and strategically located for safety and security. The following site services will be provided by the Applicant or its contractors:

- environmental, health, and safety training
- site security
- site first-aid
- construction and testing
- site fire protection and extinguisher maintenance
- furnishing and servicing of sanitary facilities
- trash collection and disposal
- disposal of hazardous materials and waste in accordance with local, state, and federal regulations

Construction materials such as concrete, pipe, wire and cable, fuels, reinforcing steel, and small tools and consumables will be delivered to the site by truck. Site access will be controlled for personnel and vehicles. The fence that will protect the site after full build-out will be installed after grading is complete, but before large components are brought into the site for assembly and installation. During the initial grading, equipment will be stored overnight and during weekends and holidays in a secure, fenced, and gated equipment storage area within the future footprint of the solar field. This area will be moved periodically to allow for completion of grading across the site.

### **1.3.5 Erosion Control and Stormwater Drainage**

During storm events, stormwater flows from northeast to southwest across the Application Area and collects in channelized and meandering washes. Project design will include review of existing stormwater drainage patterns and will inform Project grading plans. Any erosion during construction would be controlled by implementing a Stormwater Pollution Prevention Plan (SWPPP), as required by the Nevada Department of Environmental Protection (NDEP), Bureau of Water Pollution Control, and Clark County for projects disturbing more than 1 acre.

### **1.3.6 Vegetation Treatment and Weed Management**

Vegetation will be graded prior to construction. A Revegetation Plan and an Invasive Species and Noxious Weed Management Plan will be developed which will include approved mitigations and best management practices. New infestations of non-native and invasive species would be treated in accordance with the Weed Management Plan.

### **1.3.7 Health and Safety Program**

During construction of the YPSP, written safety programs and procedures will include a hearing conservation program, respiratory protection program, fall protection procedures, hot work procedures, heavy equipment procedures, and others. The site will be equipped with a comprehensive, on-site fire suppression and protection system for the O&M facilities. An emergency action plan will designate responsibilities and actions to be taken in the event of an emergency during construction of the YPSP.

## **1.4 Alternatives Considered by Applicant**

The Applicant is currently including one of the BLM-suggested alternatives as part of the Application Area. The current Application Area includes part of an original application held by Abengoa Solar and was not available to be included in the original application by the Applicant. At the suggestion of Greg Helseth with the BLM in a meeting on Tuesday, March 1, 2016, the Applicant decided to consider the Abengoa Solar area, which has since been released by Abengoa, as part of the current Application Area. As discussed in Section 1.1, amendments to the application are permitted if it is to avoid resource conflicts (BLM 2012).

Prior to this, the Applicant considered other alternative project sites in the Pahrump Valley area, one of which was the area directly to the south of the current Application Area. This area was requested in the original application to the BLM, however the Applicant was informed that the area was already part of another application held by BrightSource Energy.

Another area considered, but eliminated after further analysis, was a site on the northeast side of SR 160 that was closer to the Sandy Valley Substation. Though this site location would decrease the length of the needed gen-tie transmission line to deliver power, it would directly impact the Greater Trout Canyon desert tortoise translocation area on the northeast side of the highway. The Greater Trout Canyon Translocation Area is approximately 59,000 acres and received 800 tortoises from the Desert Tortoise Conservation Center in 2013 (BLM 2013).

## **1.5 Other Federal, State, and Local Agency Permit Requirements**

The YPSP is located on federal land managed by the BLM and is required to go through the NEPA process for environmental review. Other federal, state, and local agency involvement would be completed as part of this process. In addition, coordination with Clark County would be undertaken when applicable.

Table 2 lists the permits and authorizations that will be required and obtained prior to the commencement of construction.

**Table 2.** Summary of Permits Required or Potentially Required

Authorization	Agency or Authority	Statutory Reference	Permit or Authorization Trigger
<b>Federal</b>			
Right-of-Way for Land under Federal Management	BLM	Federal Land Policy and Management Act of 1976 (Public Law [PL] 94-579; 43 United States Code [USC] 1761–1771; 43 Code of Federal Regulations [CFR] 2800)	Federal land, federal permit, federal funding (i.e., federal nexus).
NEPA Compliance to Grant ROW	BLM	NEPA (PL 91-190, 42 USC 4321–4347, January 1, 1970, as amended by PL 94-52, July 3, 1975; PL 94-83, August 9, 1975; and PL 97-258, 4(b), September 13, 1982)	Federal nexus.
Endangered Species Act (ESA)	U.S. Fish and Wildlife Service (USFWS)	ESA (PL 93-205, as amended by PL 100-478 [16 USC 1531, <i>et seq.</i> ])	Section 7 ESA triggered by “take” of listed species, with a federal nexus; Section 10 ESA (Clark County Multiple Species Habitat Conservation Plan [Clark County 2000]) triggered by “take” of listed species, without a federal nexus.
Migratory Bird Treaty Act	USFWS	16 USC 703–711; 50 CFR Subchapter B	No permit available allowing take of migratory bird.
Bald and Golden Eagle Protection Act	USFWS	16 USC 668-668(d)	Eagle use in the Application Area.
Clean Water Act (CWA)	USACE	CWA Section 404	Placement of dredged or fill materials in waters of the U.S. or wetlands requires a federal permit.
National Historic Preservation Act (NHPA) Compliance	Nevada State Historic Preservation Office (SHPO)	NHPA 106 (PL 89-665; 16 USC 470 <i>et seq.</i> )	Federal nexus.
No Hazard Declaration	Federal Aviation Administration	49 USC 1501; 14 CFR 77	Required if structures are greater than 200 feet tall in designated airport areas.
Consultation Regarding Military Radar	Department of Homeland Security	Not applicable	Recommended if structures are over 100 feet tall.
<b>State</b>			
NHPA 106 Determination of Effect Concurrence	Nevada SHPO	16 USC 470 <i>et seq.</i> , NRS 383	Federal nexus or human remains are discovered.
Utilities Environmental Protection Act (UEPA) – Permit to Construct	Public Utilities Commission of Nevada	NRS 704.820–704.900, Nevada Administrative Code (NAC) 704.9063, NAC 704.9359– 704.9361	Greater than 70-MW renewable energy facility or a 200-kV transmission line
Rare and Endangered Plant Permit	Nevada Division of Forestry	NRS 527.260–527.300	Removal of critically endangered plants.

**Table 2.** Summary of Permits Required or Potentially Required, Continued

<b>Authorization</b>	<b>Agency or Authority</b>	<b>Statutory Reference</b>	<b>Permit or Authorization Trigger</b>
<b>State, Continued</b>			
Desert Tortoise and Gila Monster Handling Permit	Nevada Department of Wildlife	NAC 503.093	Handling of protected wildlife.
Native Cacti and Yucca Commercial Salvaging and Transportation Permit	Nevada Division of Forestry	NRS 527.050–527.110	Removal or possession of six or more protected cacti in any 1 calendar day or of less than six for 7 or more consecutive calendar days.
Incidental Take Permit	Nevada Department of Wildlife	NRS 503.584–503.589	Capture, removal, or destruction of a fully protected species.
CWA, Section 401	NDEP, Bureau of Water Quality Planning	33 USC 1251 <i>et seq.</i>	Discharge into a water, wash, or wetland connected to a navigable water.
CWA, Section 402 National Pollutant Discharge Elimination System Notification for Stormwater Management during Construction	NDEP	33 USC 1251 <i>et seq.</i>	Construction activities larger than 1 acre that will discharge stormwater runoff from the construction site into a municipal separate stormwater sewer system or into waters of the U.S.
Groundwater Discharge Permit	NDEP, Bureau of Water Pollution	NRS 445A.300–730, NAC 445A.070–348, NAC 445A.810–925	Discharge of groundwater from construction sites into waters of the U.S.
ROW Occupancy Permit	NDOT	NRS 408.423, 408.210, NAC 408	Construction within an NDOT ROW.
Over Legal Size/Load Permit	NDOT	NRS 484.437–775, NAC 484.300–580	Exceed 80,000 pounds gross weight; or Exceed 8 feet, 6 inches in width; or Exceed 14 feet in height; or Exceed 10 feet of front or rear overhang; or Exceed 70 feet in length.
Uniform Permit (for Transportation of Hazardous Materials)	Nevada Department of Public Safety	NAC 459.979	Transportation of hazardous materials in a vehicle on a public highway.
Phase I Environmental Site Assessment	NDEP	Comprehensive Environmental Response, Compensation, and Liability Act, as amended, 42 USC 9601, <i>et seq.</i>	Recommended for liability protection during real estate transactions and purchase of real property by a person or entity not previously on title.
<b>Local Clark County</b>			
Special Use Permit	Clark County Planning Commission	Clark County Zoning Ordinance Title 30	Triggered if the activity or facility does not meet land use permit conditions or conditions need to be modified/waived.
Conditional Use Permit	Clark County Comprehensive Planning Department	Clark County Title 30	Construction in Clark County.
Dust Control Permit	Clark County Department of Air Quality and Environmental Management	Clark County Air Quality Regulations. Clean Air Act of 1977 and amendments (NRS 321.001, 40 CFR Subpart C, 42 USC 7408–7409)	Construction activities impacting greater than 0.25 acre.

**Table 2.** Summary of Permits Required or Potentially Required, Continued

<b>Authorization</b>	<b>Agency or Authority</b>	<b>Statutory Reference</b>	<b>Permit or Authorization Trigger</b>
<b><i>Local Clark County, Continued</i></b>			
Commercial Septic Holding Tank Permit	Southern Nevada Health District	NRS 439, 444.650	Septic system with less than 3,000-gallon capacity. NDEP review required if over 3,000 gallons.
Grading Permit	Clark County Civil Engineering and Clark County Building Department	Clark County Title 30.32.040	Grading activities in Clark County.
Building Permit	Clark County Comprehensive Planning Department	Clark County Title 30.32.030	Construction of a building in Clark County.
Federal Emergency Management Agency Map Review and Clark County Regional Flood Control District (CCRFCD) Plan Compliance	CCRFCD	CCRFCD Uniform Regulations for Control of Drainage	Requires an approved drainage study for sites associated with construction of a new facility requiring more than 2 acres within a Clark County, Nevada, ROW.

## **1.6 Financial and Technical Capability of Applicant**

Yellow Pine Solar, LLC, is a subsidiary of NextEra Energy Resources, LLC, which is a wholly-owned subsidiary of NextEra Energy Capital Holdings, Inc. NextEra Energy Capital Holdings, Inc., is a wholly-owned subsidiary of NextEra Energy, Inc., and holds the capital stock and provides funding for the NextEra Energy, Inc., operating subsidiaries other than Florida Power & Light Company. NextEra Energy Capital Holdings, Inc., is a holding company that derives substantially all of its income from its subsidiaries. NextEra Energy Resources, LLC, owns, develops, constructs, manages, and operates domestic electric-generating facilities that sell power in wholesale energy markets.

NextEra Energy Resources, LLC, owns and operates the 150-MW SEGS III-VII concentrated solar trough facility at Kramer Junction and the 160-MW SEGS VIII-IX concentrated solar trough facility at Harper Lake. NextEra Energy Resources, LLC, has also completed several other solar energy projects in the Southwest, such as the Genesis Solar Energy Center and the Desert Sunlight Solar Energy Center, both in Riverside County, California; Shafter Solar Energy Center in Kern County, California; and Adelanto I and II Solar Energy Center in San Bernardino County, California. The company is a leader in solar MWs produced in the United States. NextEra Energy, Inc., is the corporate parent and a public holding company incorporated in 1984 in Florida. NextEra Energy, Inc.'s principal subsidiary is Florida Power & Light, which is engaged in the generation, transmission, distribution, and sale of electric energy within the state of Florida.

## **2.0 CONSTRUCTION OF FACILITIES**

### **2.1 Construction Process and Schedule**

#### ***2.1.1 Construction Process and Schedule***

The following subsections describe civil/structural features of the YPSP. The YPSP would be designed in conformance with the latest edition of the International Building Code, state and local requirements, and with applicable wind and seismic criteria for the Project location. The engineering, procurement, and

construction of the YPSP would be performed under multiple contracts. YPSP construction will be undertaken in a sequential approach in accordance with a Construction Plan, which will be developed and finalized prior to the start of construction in conjunction with the selected contractors.

Temporary construction laydown and parking areas would be included within the Project Area. With the exception of linear facilities, construction laydown would remain within the overall YPSP footprint. The gen-tie would have separate laydown areas, pad construction areas, and pulling areas.

During construction, temporary utilities will be provided for the construction offices, laydown area, and the Project Area. Temporary power during the construction period will be supplied primarily by diesel generators.

## CONSTRUCTION SCHEDULE

Major milestones of the YPSP construction schedule (Table 3) are as follows:

**Table 3.** Preliminary Construction Schedule (Dates to be verified upon finalizing the permit schedule)

Activity	Date
Mobilization	To Be Determined (TBD)
Access road, water supply, and staging area construction completion	TBD
Commence photovoltaic install	TBD
Complete operations and maintenance building construction	TBD
Complete substation construction	TBD
Complete parking areas and roadways	TBD
Complete grading and drainage	TBD
Complete photovoltaic installation	TBD
Commissioning and testing complete	TBD

Construction of the entire 250-MW YPSP is expected to occur over a period of 18 months, which includes mobilization, construction/installation, commissioning/testing, and demobilization. This construction schedule for each phase will be consecutive, intended to facilitate the construction of the facility, while still taking advantage of various mobilization and construction efficiencies.

The on-site workforce will consist of laborers, craftsmen, supervisory personnel, support personnel, and construction management personnel. Construction would require a monthly average of approximately 200 to 300 employees during the construction period, with labor requirements peaking at approximately 400 workers. As experience has shown, special circumstances may warrant an increased number of on-site workers for a short period of time, which is typically a few weeks.

Construction will generally occur between 7 a.m. and 7 p.m., Monday through Friday. Additional hours may be necessary to make up schedule deficiencies or to complete critical construction activities. For instance, during placement of concrete or during hot weather, it may be necessary to start work earlier to avoid some activities during high ambient temperatures. During the start-up phase of the YPSP, some activities (such as equipment and system testing) may continue 24 hours per day, 7 days per week. Table 4 depicts a proposed construction plan for the YPSP.

**Table 4. YPSP Construction Plan**

<b>Activity</b>	<b>Month</b>
Mobilization	Month 1
Delineate and mark the boundaries of the construction zone	Month 1
Establish parking and staging areas for vehicles and deliveries	Month 1
Establish laydown area(s) for materials storage/staging	Month 1–2
Clear and grub	Months 1–12
Install certified weed-free fiber rolls or silt fence at the base of slopes adjacent to delineated sensitive areas (i.e., wetlands), if any; Install or repair best management practices	Months 1–2
Road construction	Months 2–12
Assemble and erect photovoltaic trackers and panels	Months 2–16
Construct gen-tie line	Months 5–9
Construct operations and maintenance building	Months 4–5
Construct substation	Months 6–10
Commissioning and testing	Months 12–18
Commercial operation	Month 18

### **2.1.2 Construction and Operations Transportation Needs**

The YPSP will not provide on-site residential areas for construction workers. Construction workers will most likely commute from the Pahrump and Las Vegas areas. At the expected construction peak month, 400 workers will be needed. A more typical number for non-peak construction workers would be 200–300 workers.

At the peak of construction, approximately 400 vehicles carrying construction workers will be driving to and from the Project Area each day during the typical a.m. and p.m. peak hours. In addition, while the majority of workers are expected to arrive and depart during these peak hours, specialty workers are expected to arrive on-site during non-peak hours. Approximately 25 trucks per day are expected to deliver various materials and construction equipment during non-peak periods, and five trucks per day during peak periods.

With construction complete, the operation of the YPSP will require approximately 5–10 permanent employees working a single shift. Depending on final design, the site could potentially operate without permanent staff as an unmanned facility. The typical employee traffic is not expected to occur until after the peak period of construction is completed. A Traffic Management Plan will be prepared.

### **2.1.3 Civil Works Description**

#### **SITE PREPARATION / SURVEYING / STAKING**

Prior to the commencement of construction, a land surveyor will obtain or calculate benchmark data, grades, and alignment from plan information and provide control staking to establish the alignments, benchmarks, and elevations. The detailed design documents will furnish data for the horizontal and vertical control points and horizontal alignments, profiles, and elevations. During construction, the surveyor will reestablish and set additional control points to maintain the horizontal and vertical control points as needed.



## **SITE CLEANING / GRADING / EXCAVATION**

Prior to initiation of grading operations, the construction areas will be cleared and grubbed of vegetation and miscellaneous debris. All vegetation and debris will be stockpiled and then properly disposed of off-site or vegetation may be graded and used on-site as mulch. The primary grading activities will be associated with the solar field, and main access road, with lesser quantities associated with facility buildings, parking areas, YPSP substation, and the associated foundations.

For foundation areas, grading will consist of the excavation and compaction of earth to meet the design requirements. Grading within the solar field will match existing grades as close as possible. Some existing contours will need to be smoothed out for access purposes.

Materials suitable for compaction will be stored in stockpiles at designated locations using proper erosion prevention methods. Materials unsuitable for compaction, such as debris and large rocks, will be stockpiled at designated locations for subsequent disposal at an acceptable off-site location. Contaminated materials are not anticipated, but if any are encountered during excavation, they will be disposed of in accordance with applicable laws, ordinances, regulations, and standards.

The portions of the Project Area that will be graded are expected to result in a balanced cut-and-fill quantity of earthwork to maintain the existing conditions to the extent practical for the protection of the equipment and facilities. Fill would be compacted as necessary, and appropriate dust abatement measures implemented. These measures may include restriction of vehicle speeds, watering of active areas, watering of stockpiles, watering on roadways, track-out control at site exits, and other measures.

## **MAJOR EQUIPMENT INSTALLATION**

Construction of the tracker/mounting assemblies may be conducted in a single area and then the assemblies would be transported to the proper location and placed on the pre-installed supports. Alternately, the array assembly may occur at the installation point. Final assembly typically involves tractors, and forklifts to place the tracker/mounts onto the support structures. During this work, there will be multiple crews working the site with vehicles, including special vehicles for transporting the arrays.

The tracker/mount installations will be constructed using driven steel posts or possibly concrete foundations if required. As the solar arrays are installed, the balance of the plant will be constructed concurrently. Within the solar fields, the electrical and instrumentation/control wiring will be installed in underground trenches. The wiring will be run to the location of the solar field controls and the circuits will be checked.

The construction of the YPSP substation would begin early in the construction process. Heavy foundations and equipment pads will be constructed using trenching machines, compactors, concrete trucks and pumpers, vibrators, forklifts, boom trucks, and large cranes. Similar to site grading and excavation, appropriate dust abatement measures will be identified in a YPSP Dust Control Plan. The O&M building foundation and framework for the buildings will be placed as the construction progresses.

## **TESTING AND COMMISSIONING**

After the equipment is connected, electrical service will be verified, motors checked, and control logic verified. The various hydraulic systems and electrical transformers will be charged with their appropriate fluids and go through individual start-up testing. Once all of the individual systems have been tested, the overall plant will be ready to be tested under fully integrated conditions.

### **2.1.4 Generation Tie-Line Construction Sequence**

The gen-tie line would be constructed with crews working continuously along the gen-tie ROW. Construction of the entire gen-tie line will include the following activities:

- Preparation of marshaling yards
- Access road and spur road construction
- Clearing and grading of pole sites
- Foundation preparation and installation of poles
- Conductor installation
- Clean-up and site reclamation

Various construction activities would occur during the construction process, with several construction crews operating simultaneously at different locations. Similar to YPSP site development, appropriate dust abatement measures will be identified in the YPSP Dust Control Plan. These measures may include restriction of vehicle speeds, watering of active areas, watering of stockpiles, watering on roadways, track-out control at site exits, and other measures. The following subsections describe in more detail the construction activities associated with the YPSP's gen-tie line.

#### **MARSHALING YARDS**

Construction staging/laydown and parking areas are proposed in the YPSP Project Area. Construction materials such as concrete, wire and cable, fuels, and small tools and consumables would be delivered to the staging/laydown areas by truck.

#### **ROAD WORK**

The construction, operation, and maintenance of the proposed gen-tie line would require that heavy vehicles access structure sites along the ROW. The YPSP proposes to use the newly constructed site access road, and other existing roads north of the Project Area, for all construction, operation, and maintenance activities associated with the gen-tie line. New spur roads approximately 14 feet wide and averaging 20 feet in length, would be cleared from the access road to the structure sites. Each spur road would lead to a construction pad for a pole structure.

#### **POLE PADS**

At each site, a work area would be required for the structure footing location, structure assembly, and the necessary crane maneuvers. The work area would be cleared of vegetation only to the extent necessary, and the construction pad would be leveled to facilitate the safe operation of equipment, such as construction cranes.

#### **POLE ERECTION**

Transmission line pole structure foundation would be excavated with power drilling equipment if required. A vehicle-mounted power auger or backhoe would be used to excavate for the structure foundation. Although not expected, in some instances blasting could be necessary because of specific geologic conditions.

Installation of new structures to support the 230-kV bundled circuit would begin with the excavation of foundations or the direct burying of poles. A truck-mounted auger, backhoe, or similar equipment would typically be used for excavation of this type. Once the foundation holes have been cleaned and the

foundations poured, the poles with preassembled insulators, hardware, and stringing sheaves would be lifted into position.

### CONDUCTOR INSTALLATION

Typical conductor stringing activities are illustrated in Figure 3. Crossing structures would be erected adjacent to the existing transmission line and roadways or other structures requiring protection during conductor installation. Crossing structures would prevent ground wire, conductors, or equipment from falling on an obstacle, and would be removed following the completion of conductor installation.

Equipment for erecting the crossing structures would be the same as the equipment discussed above for transmission pole installation. Crossing structures may not be required for small roads or other areas where suitable safety measures such as barriers, flagmen, or other traffic controls could be used.

Pilot lines would be pulled (strung) from structure to structure and threaded through the stringing sheaves at each structure. This phase of work may be accomplished through the use of helicopters to minimize or otherwise eliminate the need to traverse the ROW along the ground from structure to structure. Following the pilot lines, a larger diameter, stronger line would be attached to the conductors to pull them onto the structures. This process would be repeated until the ground wire or conductor is pulled through all sheaves.

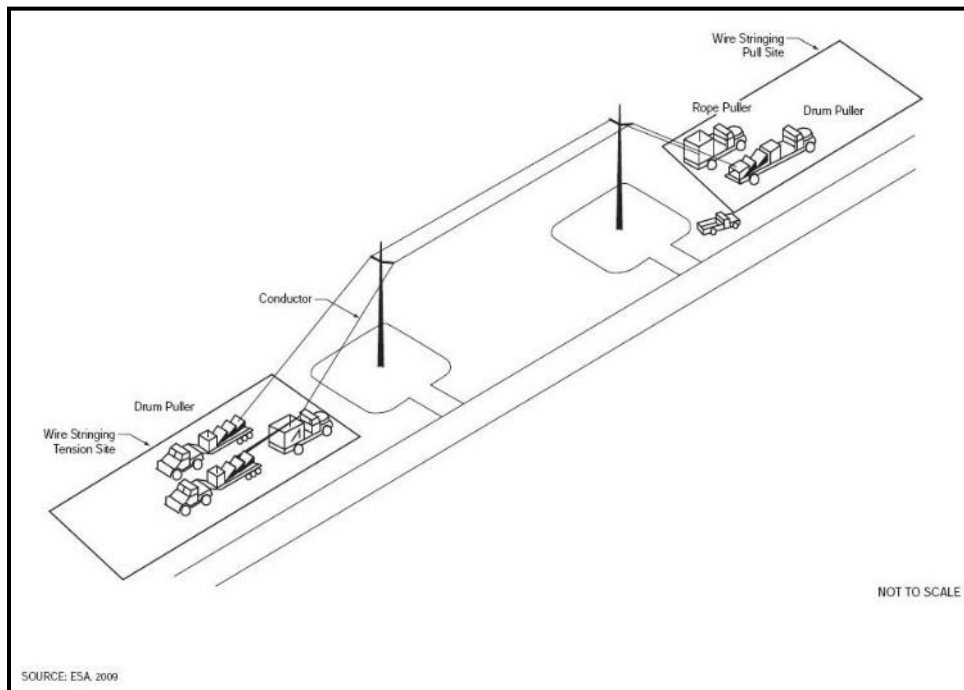

**Figure 3.** Illustration of transmission line conductor stringing.

### PULLING SITES

The conductors would be strung using powered pulling equipment at one end. Powered braking or tensioning equipment would be approximately 1 mile apart. Tensioners and/or pullers, line trucks, wire trailers, and tractors needed for stringing and anchoring ground wire or conductor would be necessary at each pulling site. The tensioner, in concert with the puller, would maintain tension on the conductors while they are being pulled through the structures.

## **CLEAN UP AND SITE RECLAMATION**

Construction sites, material storage yards, and access roads will be kept in an orderly condition throughout the construction period. Approved enclosed refuse containers will be used throughout the Project Area. Disturbance will be carefully planned and minimized during construction. The post-construction ROW will be restored as required by the BLM. All practical means would be made to restore the land to its original natural contours.

## **3.0 RELATED FACILITIES AND SYSTEMS**

### **3.1 Transmission System Interconnect**

#### ***3.1.1 Existing and Proposed Transmission System***

Nearly all of the power produced by the YPSP will be delivered to the grid. Any power needed at the site for plant auxiliaries such as control systems, and general facility loads including lighting and heating, ventilation, and air conditioning, will be provided from external sources and not from the generation on-site.

The existing Sandy Valley Substation is located southeast of the YPSP. The net power produced by the facility will be delivered to the Substation via either a newly constructed 7- to 10-mile-long, 138-kV transmission line (Gen-Tie Alternative 1) or a loop-in to the existing VEA 230-kV line (Gen-Tie Alternative 2) from a newly constructed project substation. Gen-Tie Alternative 1 would originate at the YPSP switchyard and would be constructed within the BLM-designated utility corridor.

#### ***3.1.2 Ancillary Facilities and Substations***

The YPSP would require the construction of a new, approximately 200 × 200-foot switchyard on BLM lands within the Project Area. This switchyard could be larger depending on the interconnection agreement since a loop-in to an existing line would require a larger footprint. The switchyard would be a series of 35-kV breakers for collection of power from the solar field, a common bus, and a step-up transformer. The switchyard will utilize tubular aluminum alloy bus. Tube, cables, and support structures will meet all electrical and mechanical design requirements. Instrument transformers (current and capacitive voltage transformers) will be included for protection. Shield wires and lightning arrestors will be included to protect switching station equipment and personnel against lightning strikes. Final switchyard equipment will be determined during final engineering of the proposed interconnection.

#### ***3.1.3 Status of Power Purchase Agreements***

Before construction of the YPSP begins, a Power Purchase Agreement (PPA) is needed with a local municipal utility, a California Investor Owned Utility, or large industrial business to buy the power produced at the plant. Applicant does not currently have a PPA with any local or regional electric utility.

#### ***3.1.4 Status of Interconnect Agreement***

An interconnection agreement has not been tendered at this time. Yellow Pine Solar, LLC, has filed an interconnection request with the California Independent System Operator (CAISO) and is in the evaluation process.

### **3.1.5 General Design and Construction Standards**

The proposed transmission line structures will consist of monopole structures reinforced as necessary to withstand design loads. These are installed by the excavation of foundations approximately 4 feet in diameter and up to 20 feet in depth, depending on soil conditions. Once the poles are lifted into position, the holes would be backfilled using native soils, gravel, or concrete, as appropriate. The lines will be insulated from the poles using insulators engineered for safe and reliable operation. Shield wires will be included along the length of the lines to protect against lightning strikes. These same structures will carry a single, insulated, fiber-optic line to provide one part of the needed redundant communications system.

## **3.2 Other Related Systems**

### **3.2.1 Communications System Requirements (Microwave, Fiber Optics, Hard Wire, Wireless) During Construction and Operation**

The YPSP requires a supervisory control and data acquisition (SCADA) system to keep track of the plant, control production, respond to demands on the grid, and be able to take the plant off-line quickly if required for grid operation or safety reasons. SCADA refers to a system that collects data from various sensors throughout the plant then sends it to a central computer, which then manages and controls the data. It also refers to that part of the system that communicates with the rest of the grid. To comply with the grid interconnect, the YPSP must provide redundant communications to the plant. Technology is changing rapidly in the field of plant control communications, but for the purposes of this POD, Applicant assumes that some kind of physical connection will be needed and plans to install it overhead on the proposed transmission line.

## **4.0 OPERATIONS AND MAINTENANCE**

### **4.1 Operations Staff and Vehicles**

The YPSP would be staffed by up to 10 operations personnel during the site's daytime working hours. Operations personnel will work a single shift from 7 a.m. to 4 p.m., Monday through Friday. During time periods when the facility is not fully staffed, the YPSP would be monitored remotely from Applicant's parent company's Fleet Performance and Diagnostic Center in Juno Beach, Florida. If emergency conditions are encountered, YPSP staff would be notified and would return to the facility, as required. Specialty personnel may also be located on-site during non-working hours to perform specific maintenance functions as required.

Operation and maintenance vehicles would include ¾-ton pick-up trucks and small utility vehicles to perform on-site welding, lubricating, panel washing, and other maintenance activities. In addition, flatbed trucks, dump trucks, and front-end loaders may be present on-site at various times. Heavy-haul transport equipment would be brought to the site as needed for any major maintenance or equipment repair or replacement.

### **4.2 Operation and Maintenance Activities**

The plant would be maintained by staff personnel for normal preventive maintenance. This would include daily inspection of field components, condition assessment of critical equipment, and routine lubrication of equipment. The YPSP facilities would be repainted on a regular basis to maintain its appearance and protect it from the elements.

The PV panels will be washed up to four times per year to increase the average optical transmittance of the flat panel surface. Panel washes are likely to occur during off-peak hours. The demand for water to wash the panels is approximately 50,000 gallons per day.

Road maintenance would be performed, as needed. Paved roads would be swept, sealed, and/or overlaid as needed to preserve the asphalt surface from degradation. Potholes or damage to the road will be repaired as soon as practical. Grading and drainage would be maintained for gravel and earthen roads. Water would be applied, as required, to limit fugitive dust.

The YPSP may operate as either a manned or unmanned site to be determined after final design. Under normal circumstances for an unmanned site, the YPSP substation would be controlled remotely, and routine inspections by personnel would occur on a weekly basis or as needed under emergency conditions. In addition, all of the YPSP substation structures would be annually inspected from the ground for corrosion, misalignment, and foundation condition. Ground inspection would include the inspection of hardware, insulator keys, and conductors. This inspection would also check conductors and fixtures for corrosion, breaks, broken insulators, and bad splices.

Electric lines, support systems, and instrumentation and controls would be inspected regularly to ensure the safe, efficient, and economical operation of the YPSP.

Any water storage tanks installed as part of the YPSP would require frequent inspection and may need occasional repairs. This maintenance would include routine painting of the storage tanks to protect them from corrosion.

## **4.3 Water Use and Waste Management**

### **4.3.1 Water Use**

The Applicant is exploring options to buy commercial water or purchase or lease existing water rights and construct a new well.

Initial construction water usage will be in support of site preparation and grading activities. During earthwork for the grading of access roads, foundations, equipment pads, and YPSP components, the main use of water will be for compaction and dust control. Smaller quantities will be required for preparation of the concrete required for foundations and other minor uses. Subsequent to the earthwork activities, water usage will be in support of dust suppression and normal construction water requirements that are associated with construction of the building, substation, internal access roads, and solar arrays. The total water usage during construction will be approximately 600 acre feet over an 18-month period.

The PV technology proposed for the YPSP does not require water for the generation of electricity. During operations, water use will be limited primarily to PV array washing with the potential for periodic dust control and maintenance applications. Drinking (potable) water will be supplied for workers on-site, and is estimated to be approximately 300 gallons per month varying seasonally and by work activities.

The amount of water required to clean the PV modules four times per year is estimated to be about 8 million gallons per year, approximately 25 acre feet per year (AFY). Depending on site events and conditions, the cleaning frequency may be less. The water used for module cleaning is not anticipated to require disposal due to the extremely high evaporation rate at the site.

Based on the anticipated uses, the estimated quantity of water needed for operation of the YPSP will be approximately 25 AFY. This assumes no generation of wastewater on-site that would require treatment.

### **4.3.2 Water Treatment**

The panel washing water would require an on-site demineralizer treatment process. The water treatment plan will be developed based on receipt of additional site-specific water quality data.

An on-site tank or tanks would contain the demineralized water. This would have the capacity of approximately 100,000 gallons, which is the approximate water usage for 2 days of washing if the entire YPSP's PV panels will be washed in 40 days.

## **4.4 Waste Management**

YPSP wastes would include wastewater, nonhazardous solid waste, hazardous solid waste, and hazardous liquid waste. A variety of safety-related plans and programs will be developed and implemented to ensure safe handling, storage, and use of hazardous materials. Plant personnel will be supplied with appropriate personal protective equipment (PPE) and will be properly trained in the use of PPE and the handling, use, and cleanup of hazardous materials used at the facility, as well as procedures to be followed in the event of a leak or spill. Adequate supplies of appropriate cleanup materials will be stored on-site.

### **4.4.1 Hazardous Chemicals**

A variety of hazardous materials will be used and stored during construction and operation of the YPSP, as summarized below. Hazardous materials that will be used during construction include gasoline, diesel fuel, oil, lubricants, and small quantities of solvents and paints. During construction, all hazardous materials will be stored on-site in storage tanks/vessels/containers that are specifically designed for the characteristics of the materials to be stored. The storage facilities will include secondary containment in case of tank/vessel failure.

During operations, hazardous materials that may be used at the facility will be stored inside the O&M building to prevent exposure to the elements and reduce the potential for accidental releases. The chemicals will be segregated by type, and spill containment will be provided inside the warehouse building storage area.

The quantities stored on-site will be evaluated to identify the required usage and maintain sufficient inventories to meet use rates without stockpiling excess chemicals. Those chemicals that may be present may include some or all of the following:

- Fuel (diesel)
- Fertilizers
- Hydraulic fluid
- Transformer oil

### **4.4.2 Wastewater**

The sanitary wastewater system will collect sanitary wastewater at the O&M building. Portable chemical toilets will be provided for construction workers in the solar fields. The sanitary wastewater from sinks, toilets, showers, and other sanitary facilities in the O&M building will be discharged to a sanitary septic system and either an on-site leach field or pump-out holding tank. The septic system will be permitted and designed in accordance with all state and county regulations.

#### **4.4.3 Solid and Non-Hazardous Waste**

Construction, operation, and maintenance of the YPSP will generate non-hazardous solid wastes typical of power generation or other industrial facilities. The plant wastes that are produced will include oily rags, worn or broken metal and machine parts, defective or broken electrical materials, other scrap metal and plastic, insulation material, empty containers, paper, glass, and other miscellaneous solid wastes including the typical refuse generated by workers. These materials will be disposed by means of contracted refuse collection and recycling services. Waste collection and disposal will be in accordance with applicable regulatory requirements to minimize health and safety effects.

#### **4.4.4 Hazardous Solid and Liquid Wastes**

Small quantities of hazardous wastes will be generated during construction and operation of the YPSP. Hazardous wastes generated during the construction phase will include substances such as paint and primer, thinners, and solvents. Hazardous solid and liquid waste streams generated during operations include substances such as used hydraulic fluids, oils, greases, filters, etc., as well as spent cleaning solutions and spent batteries. A Spill Prevention and Countermeasure and Control Plan, and Hazardous Materials Plan will be developed prior to construction.

### **4.5 Termination and Reclamation**

The YPSP would have a useful life of at least 25–40 years. Applicant would be required to post a reclamation bond as a condition of authorization issuance. The value of this bond would be determined subject to BLM policy, and remains to be determined. At the end of the useful life of the facility and the termination of the ROW grant, Applicant would remove all improvements. During improvement removal, the site would remain fenced and gated. Materials that could be reused or recycled would be hauled away from the site and sold. Materials that could neither be reused nor recycled would be dismantled and hauled to the nearest approved landfill. Hazardous materials that could not be reused or recycled would be disposed of at approved facilities. Applicant would remove foundations to 3 feet below ground surface, restore contours over the foundations to pre-project conditions, remove the stormwater management berms, and restore the pre-project contours to the maximum extent possible. During these reclamation operations, it is anticipated that fugitive dust abatement measures comparable to those applied during the YPSP construction would be implemented. A Decommissioning and Site Reclamation Plan would be prepared.

The transmission line and towers may be removed. Some structures and equipment may be required to remain in place based on final interconnection agreements. Conductors and tower steel would be sold for reuse or recycling. The YPSP substation, including all structures and fencing, would be removed. Foundations for the towers and substation facilities would be removed to 3 feet below ground surface and contours restored.

It is not possible to predict the conditions and management objectives that would exist at the time of decommissioning. Therefore, decommissioning details would be developed and provided to BLM when the time for permanent closure is closer and more information is available. The BLM would require Applicant to submit an abandonment plan that would be reviewed and revised as needed in order to be approved by the BLM. The plan would include all activities required to dispose of or store all hazardous and toxic materials and chemicals associated with the YPSP. This plan would discuss all currently applicable laws, ordinances, regulations, and standards associated with the safe storage or disposal of these materials. The plan would also include a description of procedures for notification of regulatory agencies. The BLM would review and approve the plan.



## 5.0 ENVIRONMENTAL CONSIDERATIONS AND OTHER RESOURCES

Effects on environmental resources will be analyzed and mitigated through the NEPA process. It is anticipated that all impacts to all resources can be successfully mitigated in order to avoid significant impacts. Probable effects for the following environmental and cultural resources are summarized below.

### 5.1 General Vegetation

General vegetation found in the Application Area consists mainly of Sonora-Mojave Creosotebush-White Bursage Desert Scrub and Mojave Mid-Elevation Mixed Desert Scrub (U.S. Geological Survey 2004). The creosote-bursage ecological system is found in broad valleys, lower bajadas, plains, and low hills in the Mojave and lower Sonoran Deserts. This system ranges from sparse to moderately dense layer (2%–50% cover). Creosote bush (*Larrea tridentata*) and white bursage (*Ambrosia dumosa*) are the typical dominant species, but a variety of shrub, dwarf-shrub, and cacti may be present to co-dominant.

Typically, the loss of vegetation communities would not be considered a significant impact, unless those vegetation communities support sensitive wildlife or plant species or there are substantial amounts removed (i.e., >10% of a species' range). In some cases, a local, State, or federal agency may also provide protection to a vegetation community because it is special or unique for the area. No special or unique vegetation communities have been identified in the Application Area. Rare plants may occur in the final Project Area since there are known rare plants within 5 miles of the Application Area. These plants would be identified through BLM-approved rare plant surveys and impacts would be avoided or mitigated.

In addition to general vegetation, the BLM and the State of Nevada have protections in place for cactus, yucca, and Christmas tree species (NRS 527.060–537.120 and NAC Chapter 527). The BLM requires preparation of a Site Restoration/Revegetation and Decommissioning Plan, which includes measures to salvage these species.

Finally, noxious weeds are defined by the State of Nevada as “any species of plant which is, or liable to be, detrimental or destructive and difficult to control or eradicate” (NRS 555.005). Preparation of a noxious weed risk assessment and completion of a Project-specific weed management plan would likely be required. In addition, the need for a Pesticide Use Plan will be evaluated throughout the environmental analysis for the YPSP and prepared in accordance with BLM guidelines if applicable.

### 5.2 General Wildlife

Wildlife in the Application Area consists of reptiles, amphibians, insects, birds, and game and non-game species found in the Mojave Desert ecosystem. Although these species are important to the Mojave Desert ecosystem, they are not afforded any special protection. Additionally, the habitats they use are widespread in southern Nevada and are not protected. Additionally, the following categories of wildlife may be impacted by development of the YPSP.

- Golden Eagle: Mortality of golden eagle (*Aquila chrysaetos*) is not anticipated to occur, though development of the Project Area may result in a loss of foraging habitat. Impact to golden eagles will be addressed as necessary in a Project-specific Bird and Bat Conservation Strategy (BBCS) which will include measures to avoid, minimize, and mitigate impacts to birds, including golden eagles.
- Avian Species: Avian species are protected under the Migratory Bird Treaty Act of 1918. Mortality of avian species is not anticipated to occur, though development of the Project Area

may result in a loss of habitat. Impacts to avian species of concern will be addressed as necessary within the BBCS.

- Big Game: Impacts to big game are not anticipated to occur from development of the YPSP.

### **5.3 Threatened and Endangered Species**

- The YPSP is located in habitat for the federally threatened Desert tortoise (*Gopherus agassizii*). YPSP development and operation may kill, injure, or displace individual desert tortoises. Project-specific mitigation measures will be provided through consultation with the USFWS, which will minimize impacts to the desert tortoise.
- Additionally, the YPSP is located in the vicinity of two tortoise translocation areas in the Pahrump Valley. The existing translocation area, Trout Canyon Translocation Area, is located to the northeast of SR 160 and received 800 tortoises in 2013 (BLM 2013). The Stump Springs Translocation Area is a proposed tortoise release area as described in the Draft Translocation Plan (USFWS 2014). Although the YPSP was identified prior to the Stump Springs Draft Translocation Plan, the Plan identifies a priority release area that overlaps with some of the YPSP Application Area. The Applicant will work with the BLM to identify measures to avoid and minimize impacts to the translocation area if it is finalized.

### **5.4 Wetlands and Jurisdictional Waters**

The U.S. Army Corps of Engineers has jurisdiction over Waters of the U.S. (WUS), including wetlands and ephemeral channels under Section 404 of the Clean Water Act. In order for an area to be classified as a wetland, it must satisfy three criteria, including vegetation (dominated by hydrophytic vegetation), hydrology (visual evidence of water), and hydric soil (saturated sufficiently to produce soil types characteristic of a wetland). For the U.S. Army Corps of Engineers to have jurisdiction over an ephemeral or intermittent wash, the wash must exhibit a distinct ordinary high-water mark (OHWM), defined as “the line on the shore established by the fluctuations of water and is indicated by physical characteristics, such as a clear, natural line impressed on the bank, shelving, changes in the character of the soil, destruction of terrestrial vegetation, the presence of litter or debris, or other appropriate means that consider the characteristics of the surrounding area” (33 CFR 328.3). In addition to exhibiting a distinct OHWM, an ephemeral wash must convey flow to WUS or provide commerce, such as crossing state lines.

An initial review of aerial photography resulted in the identification of several ephemeral washes that exhibit an OHWM. All flows observed in the Application Area are directed downstream to the southwest to a closed basin. Typically, all the channels within that flow into a closed basin are not jurisdictional WUS downstream unless they cross state lines. The ephemeral washes in the Application Area may cross state lines and could be considered jurisdictional and regulated under Section 404 of the Clean Water Act.

### **5.5 Air Quality**

Air quality is determined primarily by the type and amount of contaminants emitted into the atmosphere, the size and topography of the air basin, and the meteorological conditions. The U.S. Environmental Protection Agency has developed the National Ambient Air Quality Standards for six criteria pollutants: nitrogen dioxide (NO<sub>2</sub>), sulfur dioxide (SO<sub>2</sub>), carbon monoxide (CO), lead (Pb), ozone (O<sub>3</sub>), and particulate matter (PM).

Construction and operation will result in small amounts of dust and tailpipe emissions from vehicle traffic. All vehicles and construction equipment will be maintained to minimize exhaust emissions

and will be properly muffled to minimize noise. There would be a short-term increase in dust emissions during construction activities that would be mitigated by the application of best management practices. Disturbed areas will be watered as necessary to suppress dust, during construction and operation.

## **5.6 Visual Resources**

Visual resources (the landscape) consist of landform (topography and soils), vegetation, bodies of waters (lakes, streams, and rivers), and human-made structures (roads, buildings, and modifications of the land, vegetation, and water). These elements of the landscape can be described in terms of their form, line, color, and texture. Normally, the more variety of these elements there is in a landscape, the more interesting or scenic the landscape becomes, if the elements exist in harmony with one another. The visual impact of projects is often raised as an issue during project development. The risk is determined by evaluating the existing landscape, including current structures and developments, the proximity to viewers with high sensitivity, and how the proposed YPSP would contrast with existing conditions. The Application Area occurs in an area of public land with little surrounding development and some transmission lines. The nearest potential viewers would be citizens of Pahrump and motorists traveling on SR 160 and Tecopa Road. The construction and operation of a PV solar generating facility would result in visual contrasts to the line, color, form, and texture of the existing landscape in the Application Area. Additionally, the Application Area appears to be approximately 3 miles from the historic Spanish Trail. A Visual Contrast Analysis would be completed to fully identify potential visual impacts.

BLM lands surrounding the Application Area are managed as visual resource management (VRM) Class III and Class IV. The objective of VRM Class III is to partially retain the existing character of the landscape. The level of change to the characteristic landscape should be moderate. When taking these resources into consideration during the project planning phase, the impacts can be reduced or mitigated, and the YPSP would be in conformance with VRM Class III objectives. The objective of VRM Class IV is to provide for management activities which require major modification of the existing character of the landscape. The level of change to the characteristic landscape can be high (BLM 1986).

## **5.7 Surface and Groundwater Quality and Quantity**

The proposed YPSP is not anticipated to result in impacts to groundwater quality. A minimal amount of water would be needed during construction and would likely come from an on-site or nearby well. The Applicant will work the BLM and the State Engineer to address concerns related to water use.

## **5.8 Control or Structural Change on Any Stream or Other Body of Water**

The Application Area does not include any streams or bodies of water and there would be no change to existing bodies of water as a result of the proposed Project.

## **5.9 Existing Noise Levels**

Noise levels generated during the construction phase would vary, depending on such factors as equipment used, operation schedule, and conditions of the Application Area. Truck traffic, heavy equipment, and possibly pole foundation blasting would cause elevated noise levels at and near construction sites. Most construction activities would occur during the day, and nighttime noise levels are anticipated to drop to the background levels of the Application Area. Construction activities would last for a short period and,

accordingly, their potential impacts would be short term and intermittent in nature. There are no known sensitive noise receptors within 5 miles of the Application Area.

During facility operation, sources of noise would consist of mechanical and aerodynamic noise, transformer and switchgear noise from substations, corona noise from transmission lines, and vehicular traffic noise, all of which is expected to be negligible. Overall, the noise levels from site operation are anticipated to be lower than the noise levels associated with short-term construction activities and to be consistent with current ambient noise levels in the area.

## **5.10 Soil and Soil Stability**

Surface and subsurface soils would be removed within the Project Area. Within temporary use areas, topsoil would be removed temporarily but would be replaced following the completion of development. Soil stability issues are not anticipated to occur from development of the YPSP. Impacts to vegetation and soil would be minimized through the development and implementation of a Restoration and Reclamation Plan.

## **5.11 Cultural Resources**

A preliminary cultural resources records search will be conducted through the State Historic Preservation Office's (SHPO) Nevada Cultural Resource Information System (NVCRIS) to identify previous cultural resource projects and archeological sites within the Application Area. All cultural resources will be avoided during construction activities, resulting in a finding of no historic properties affected; in the event that cultural resources cannot be avoided, mitigation may be required.

## 6.0 LITERATURE CITED

- Bureau of Land Management (BLM). 1986. *Visual Resource Inventory*. BLM Handbook H-8410-1. Washington, D.C.: U.S. Department of the Interior, Bureau of Land Management. Available at: [http://www.blm.gov/style/medialib/blm/wo/Information\\_Resources\\_Management/policy/blm\\_ha\\_handbo.Par.31679.File.dat/H-8410.pdf](http://www.blm.gov/style/medialib/blm/wo/Information_Resources_Management/policy/blm_ha_handbo.Par.31679.File.dat/H-8410.pdf). Accessed March 18, 2016.
- . 2012. *Approved Resource Management Plan Amendments/Record of Decision (ROD) for Solar Energy Development in Six Southwestern States*. Washington, D.C.: U.S. Bureau of Land Management. October.
- . 2013. *Desert Tortoise Translocation throughout the Species Range within the Southern Nevada District and Caliente Field Office, Nevada. Environmental Assessment (DOI-BLM-NV-S010-2012-0097-EA)*. Available at: [http://www.blm.gov/style/medialib/blm/nv/field\\_offices/las\\_vegas\\_field\\_office/desert\\_tortoise\\_tr\\_translocati.Par.68909.File.dat/](http://www.blm.gov/style/medialib/blm/nv/field_offices/las_vegas_field_office/desert_tortoise_tr_translocati.Par.68909.File.dat/). Accessed March 18, 2016.
- Bureau of Land Management (BLM) and U.S. Department of Energy (DOE). 2012. *Final Programmatic Environmental Impact Statement for Solar Energy Development in Six Southwestern States*. FES 12-24, DOE/EIS-0403. Washington, D.C.: U.S. Bureau of Land Management and U.S. Department of Energy.
- Clark County. 2000. *Final Multiple Species Habitat Conservation Plan and Environmental Impact Statement for Issuance of a Permit to Allow Incidental Take of 79 Species in Clark County, Nevada*. Prepared for Clark County Department of Comprehensive Planning, Las Vegas, and U.S. Fish and Wildlife Service, Reno, Nevada. San Diego, California: RECON. Available at: <http://www.clarkcountynv.gov/airquality/dcp/Pages/CurrentHCP.aspx>. Accessed March 2016.
- U.S. Fish and Wildlife Service (USFWS). 2014. *Draft Translocation Plan Stump Springs, Clark County, Nevada*. Available at: [http://www.blm.gov/style/medialib/blm/nv/field\\_offices/las\\_vegas\\_field\\_office/desert\\_tortoise\\_tr\\_translocati.Par.77457.File.dat/20140626.Stump%20Springs%20Translocation%20Plan.draft.pdf](http://www.blm.gov/style/medialib/blm/nv/field_offices/las_vegas_field_office/desert_tortoise_tr_translocati.Par.77457.File.dat/20140626.Stump%20Springs%20Translocation%20Plan.draft.pdf). Accessed March 18, 2016.
- U.S. Geological Survey. 2004. National Gap Analysis Program. Southwest Regional Gap Analysis Project Field Sample Database. Version 1.1. Logan, Utah: RS/GIS Laboratory, College of Natural Resources, Utah State University.



## **APPENDIX A**

### **Preliminary Single-Axis Array Layout Designs**





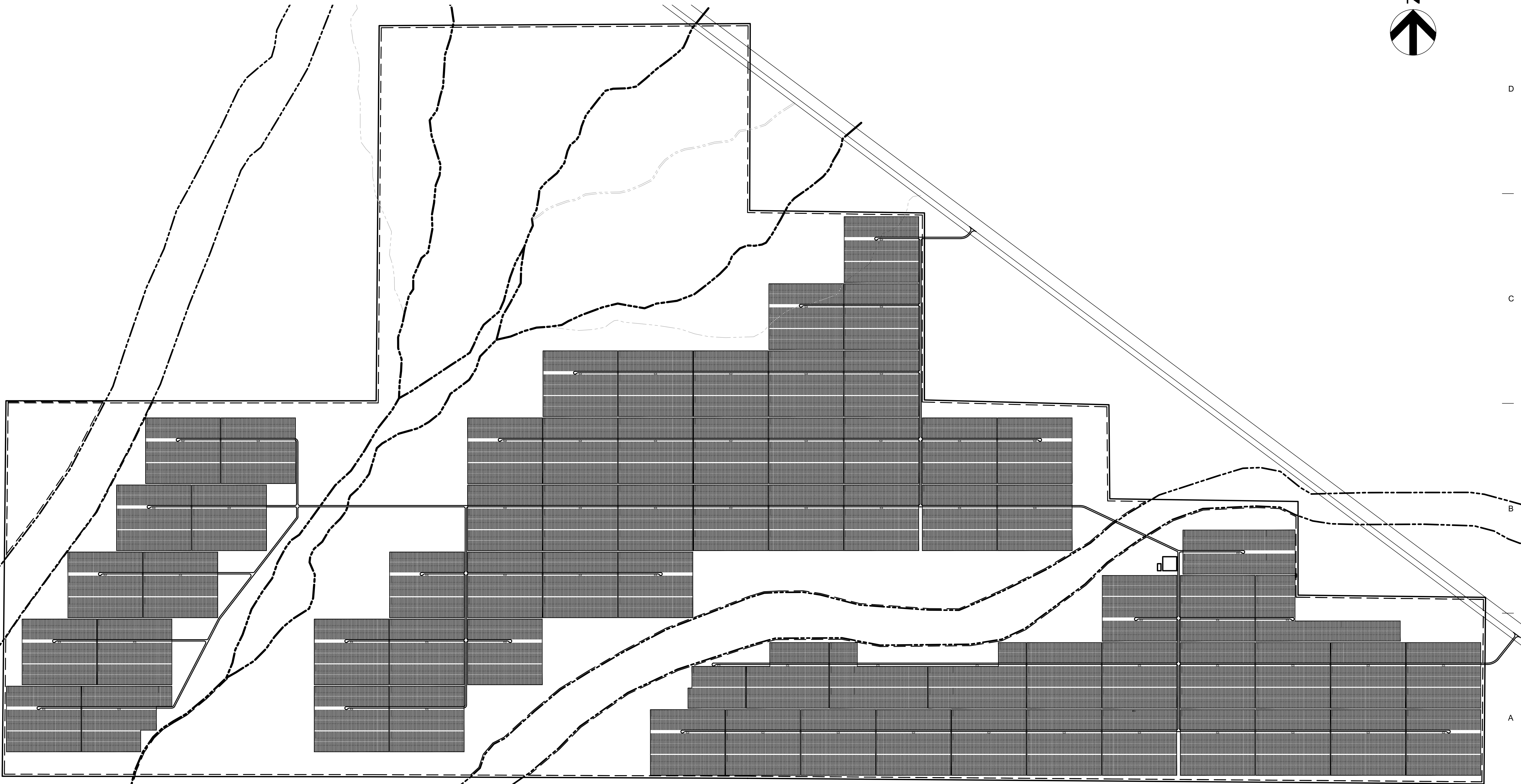
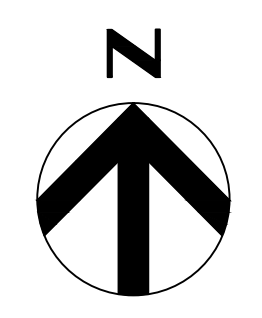

ISSUE	DATE	DESCRIPTION
0	06/13/16	PRELIMINARY 250 MW TRACKER LAYOUT

PROJECT MANAGER	D. KUVAAS
DESIGNED BY	-
CHECKED BY	-
DRAWN BY	B. SCARBOROUGH
PROJECT NUMBER	00000000277096

**YELLOW PINE SOLAR PROJECT  
SINGLE AXIS TRACKER  
250MW SOLAR FARM  
CLARK COUNTY, NEVADA**

**PRELIMINARY  
ALTERNATIVE 1 -- OPTION 1  
SINGLE AXIS ARRAY LAYOUT PLAN**

0 1" 2" SCALE 1" = 650'

FILENAME SHEET

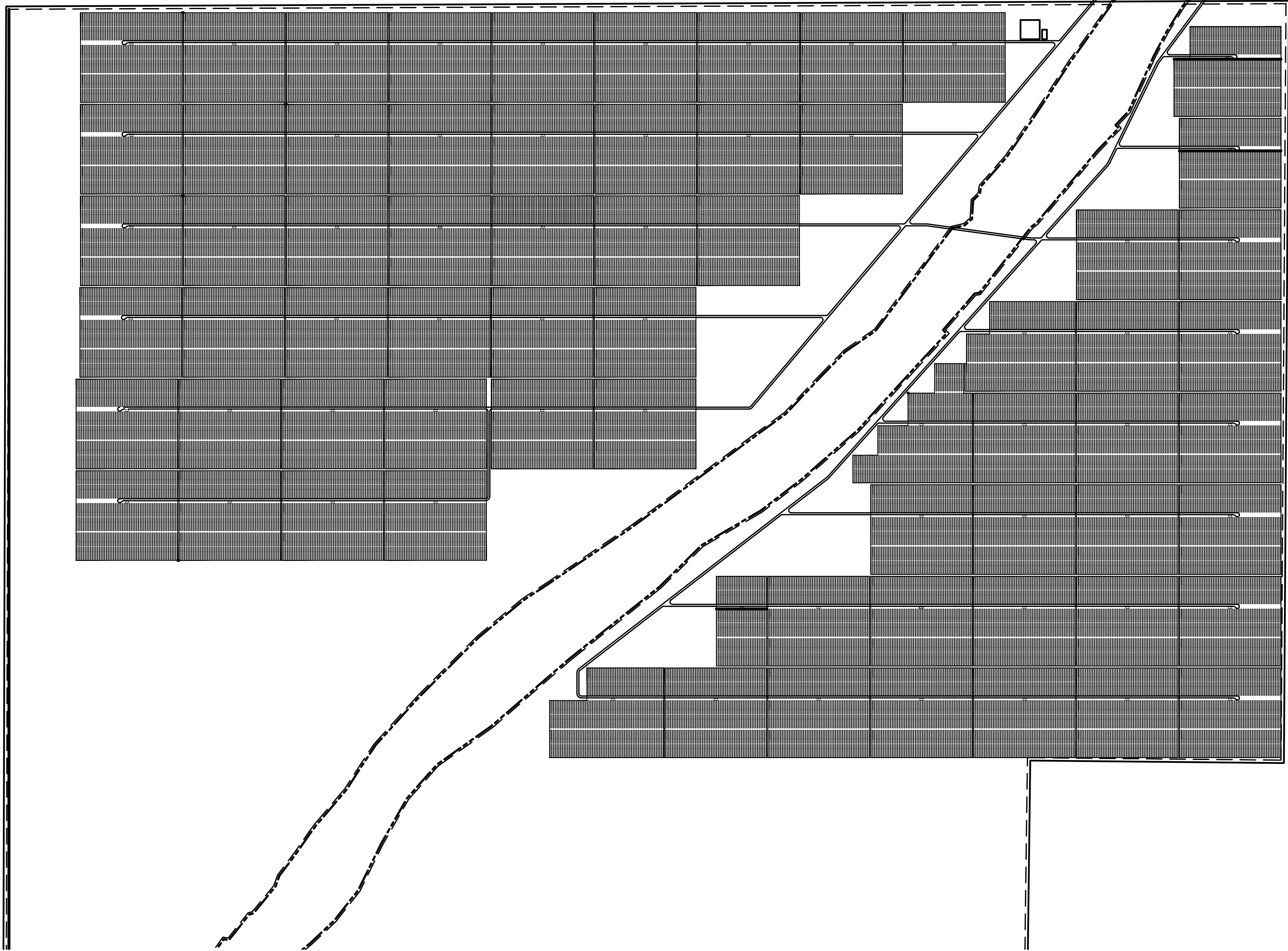
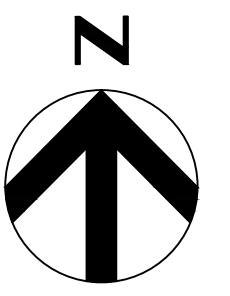

D  
—  
C  
—  
B  
—  
A

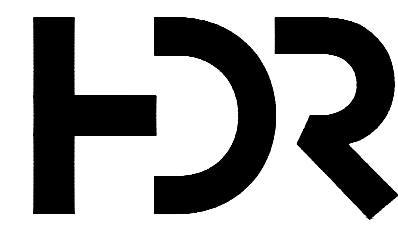

ISSUE	DATE	DESCRIPTION
0	06/13/16	PRELIMINARY 250 MW TRACKER LAYOUT

PROJECT MANAGER	D. KUVAAS
DESIGNED BY	-
CHECKED BY	-
DRAWN BY	B. SCARBOROUGH
PROJECT NUMBER	000000000277096

**YELLOW PINE SOLAR PROJECT  
SINGLE AXIS TRACKER  
250MW SOLAR FARM  
CLARK COUNTY, NEVADA**

**PRELIMINARY  
ALTERNATIVE 2 - OPTION 1  
SINGLE AXIS ARRAY LAYOUT PLAN**



FILENAME  
SCALE 1" = 650'

SHEET



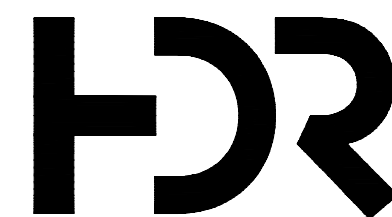
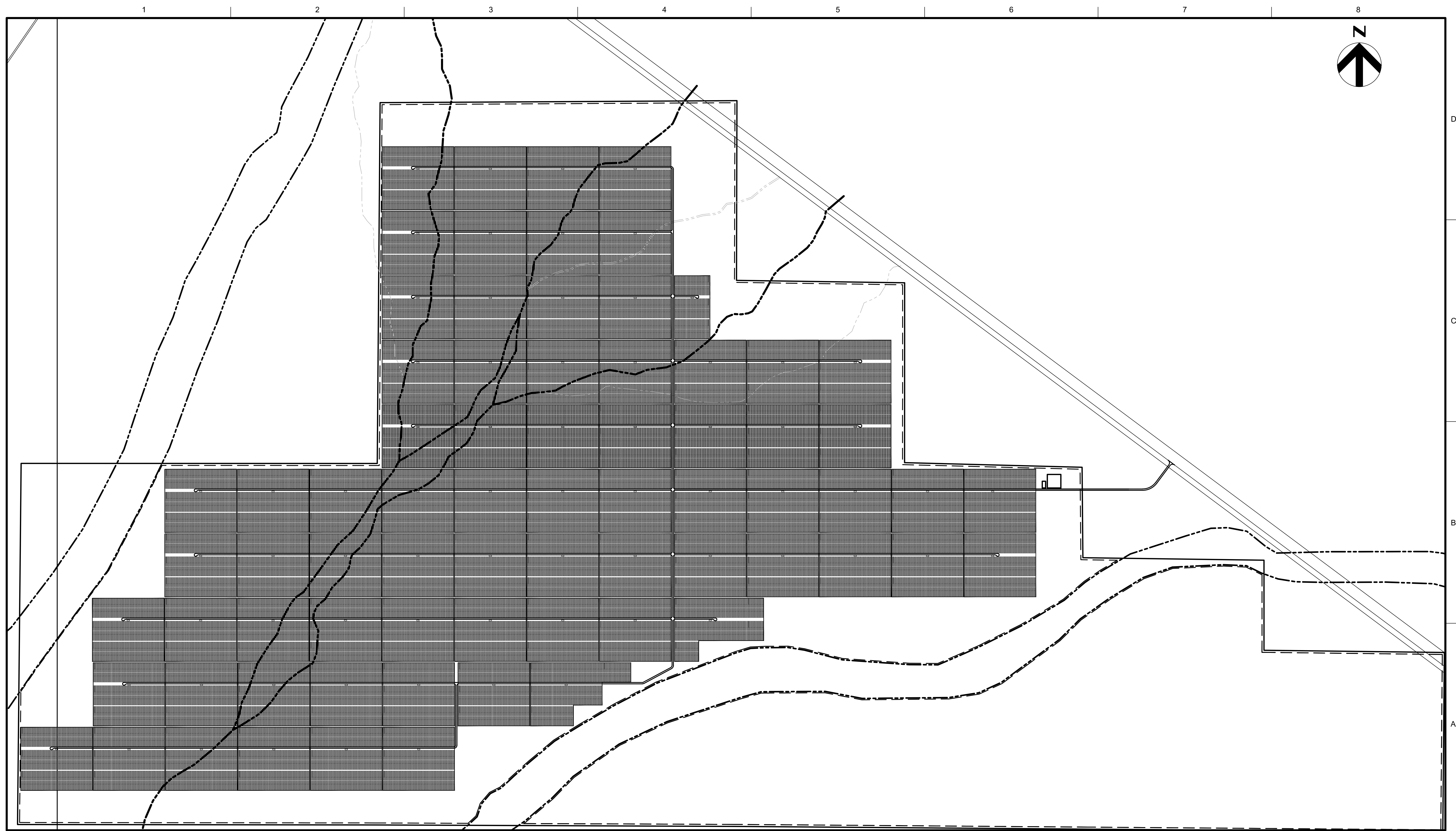

ISSUE	DATE	DESCRIPTION
0	06/13/16	PRELIMINARY 250 MW TRACKER LAYOUT

PROJECT MANAGER	D. KUVVAAS
DESIGNED BY	-
CHECKED BY	-
DRAWN BY	B. SCARBOROUGH
PROJECT NUMBER	000000000277096

**YELLOW PINE SOLAR PROJECT  
SINGLE AXIS TRACKER  
250MW SOLAR FARM  
CLARK COUNTY, NEVADA**

**PRELIMINARY  
ALTERNATIVE 1 - OPTION 2  
SINGLE AXIS ARRAY LAYOUT PLAN**



FILENAME  
SCALE 1" = 650'

SHEET

## **APPENDIX B**

### **Typical Pole Structures for Gen-Tie**



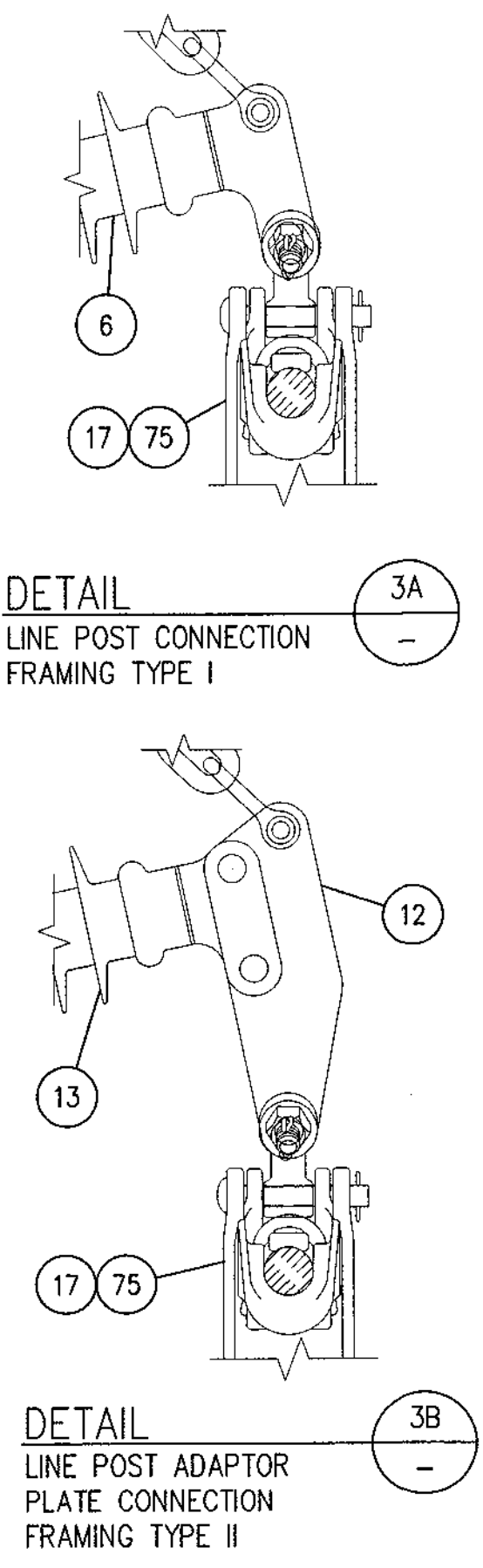
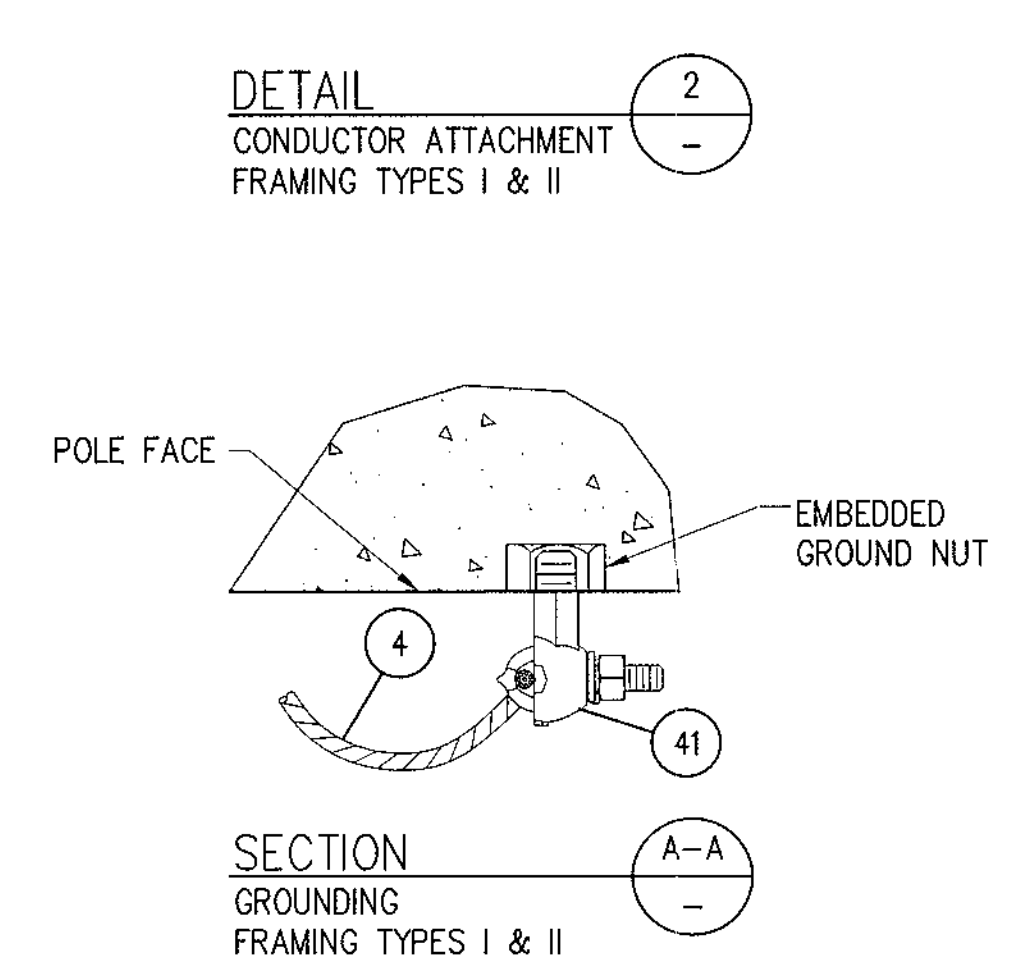
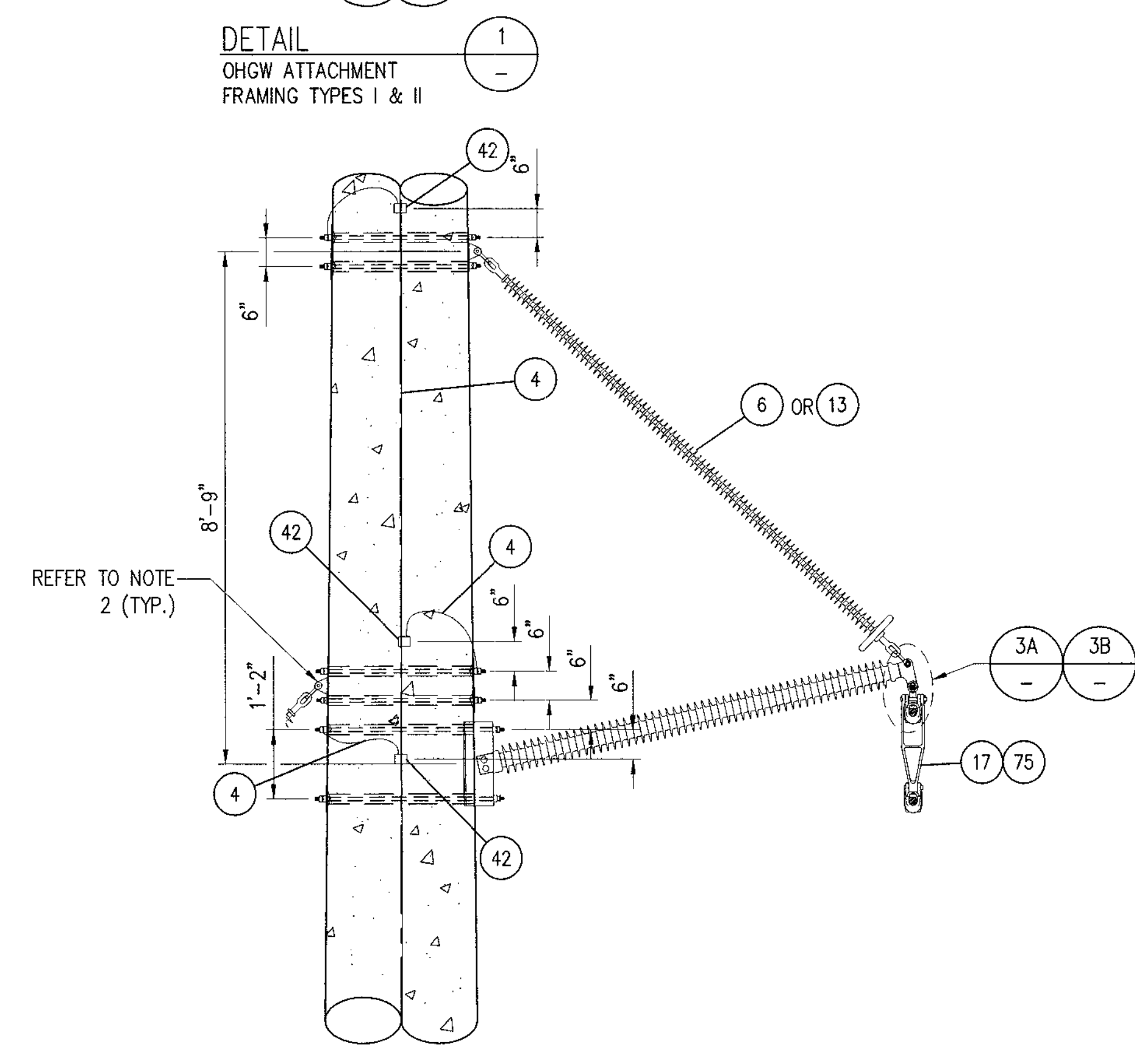
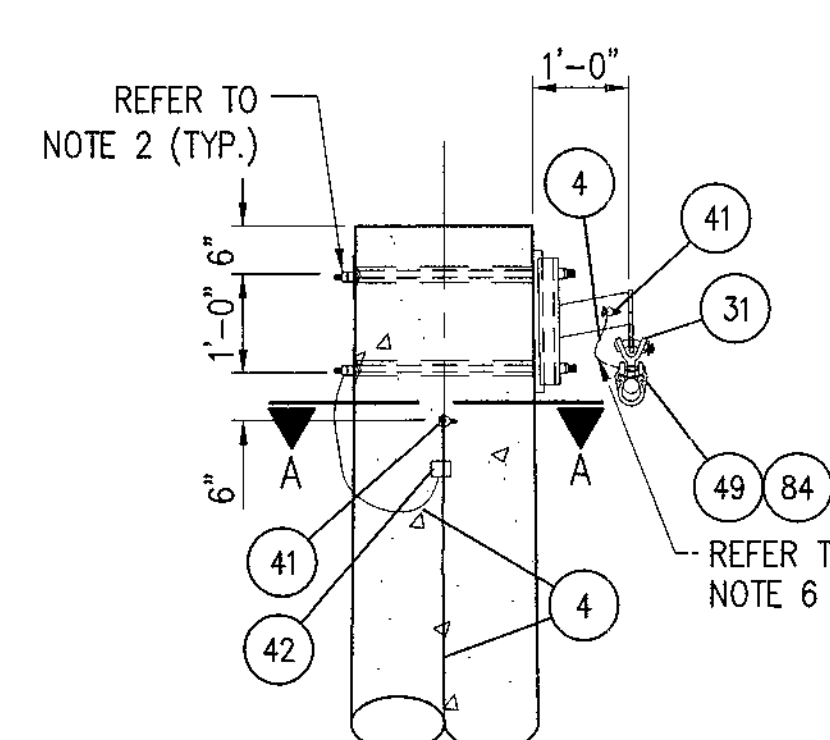
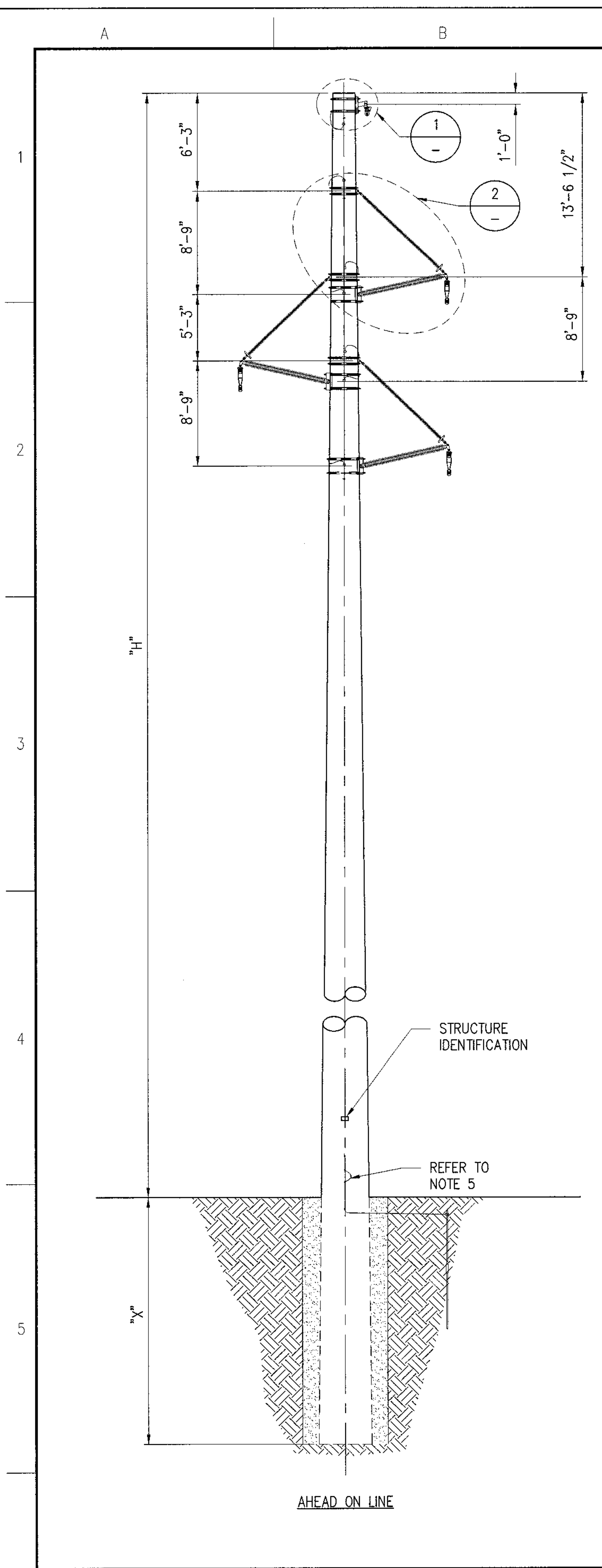

BILL OF MATERIAL			
ITEM NO.	QTY./STR. FRAMING TYPE I	QTY./STR. FRAMING TYPE II	
4	A/R	A/R	GROUND WIRE, #2 COPPER, 7-STRAND, BARE, IN FEET
6	3	0	INSULATOR ASSEMBLY, 230 kV, COMPOSITE, BRACED LINE POST, MACLEAN #B29C089AL99A
12	0	3	ADAPTOR PLATE, FOR HORIZONTAL LINE POST INSULATOR, MACLEAN #AC-7689-6 OR EQUAL
13	0	3	INSULATOR ASSEMBLY, 230 kV, COMPOSITE, BRACED LINE POST, MACLEAN #B291089AL99D
17	3	3	VERTICAL BUNDLE ASSEMBLY SUSPENSION CLAMP, WITH Y-CLEVIS EYE, MACLEAN #VBLS-18-99-Y OR EQUAL
31	1	1	Y-CLEVIS EYE, 25 KIP, HUBBELL #YCS06 OR EQUAL
41	2	2	TANK GROUND, BRONZE, 1/2"-13 UNC STUD, #8 SOL-2/0 STR, MACLEAN #TG-820 OR EQUAL
42	7	7	GROUND CLAMP, MACLEAN #J8300 OR EQUAL
49	1	1	GROUND BOND, MAIN 0.25"-0.56", TAP 0.16"-0.3", MACLEAN #BC-63 OR EQUAL
75	6	6	ARMOR ROD FOR 1272 KCM 45/7 ACSR "BITTERN", PLP #AR-0146 OR EQUAL
84	1	1	SUSPENSION CLAMP, D.I., FOR 1/2" 7-STRAND EHS, HUBBELL #MS60N OR EQUAL

A/R = AS REQUIRED

STRUCTURE TABLE					
STRUCTURE NUMBER	FRAMING TYPE	STRUCTURE HEIGHT (FT)	EMBED LENGTH "X" (FT)	ABOVE GROUND HEIGHT "H" (FT)	QUANTITY
48B, 49B	II	90	20	70	2
100B	II	105	20	85	1

- NOTES:**
- TRANSMISSION LINE STRUCTURES DESIGNED IN ACCORDANCE WITH APPLIC'S SUGGESTED PRACTICES FOR AVIAN PROTECTION ON POWER LINES AND MIGRATING BIRD COLLISIONS WITH POWER LINES (2006).
  - MOUNTING BRACKETS, DAVIT ARMS, BOLTS, NUTS, AND WASHERS SHALL BE SUPPLIED BY POLE MANUFACTURER.
  - REFER TO DRAWING BSEP-D-F008-SH1 FOR FOUNDATION DETAILS.
  - REFER TO DRAWING SET BSEP-B-T007 FOR STRUCTURAL LOADING INFORMATION.
  - REFER TO DRAWING BSEP-D-T003-SH10 FOR GROUNDING INSTALLATION DETAILS.
  - CONTRACTOR SHALL TRAIN GROUND LEAD WIRE TO FORM AN "S" SHAPE BETWEEN THE EHS ATTACHMENT & THE TANK GROUND ON THE END OF THE DAVIT ARM.

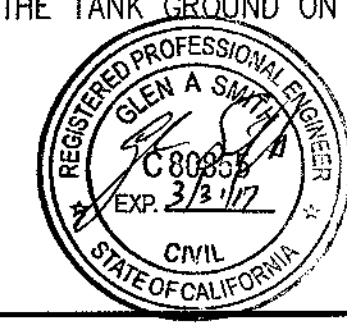

**AS BUILT**  
01/18/16

Engineering with Distinction  
**TECO** ELECTRICAL CONSULTANTS, INC.  
 BILLINGS, MONTANA

NO	REVISION	DATE	BY	APR
1	AS BUILT	18Jan2016	GS	
0	ISSUED FOR CONSTRUCTION	02Feb2015	GS	

**Nextera ENERGY**  
 AN FPL GROUP COMPANY  
 RESOURCES

ENGINEERING RECORD		DATE
DRAWN	DJW	18Jan2016
DESIGNED	MRF	18Jan2016
CHECKED	BMS	18Jan2016
APPROVED	CS	18Jan2016
DWG SCALE:	PLT SCALE:	

COLORADO RIVER - DRACKER  
 230 kV TRANSMISSION LINE PROJECT  
 SGL. CIR. CONC. TANGENT STR.

DWG. NAME: BSEP-D-T003-SH1 | REVISION NO.: 1



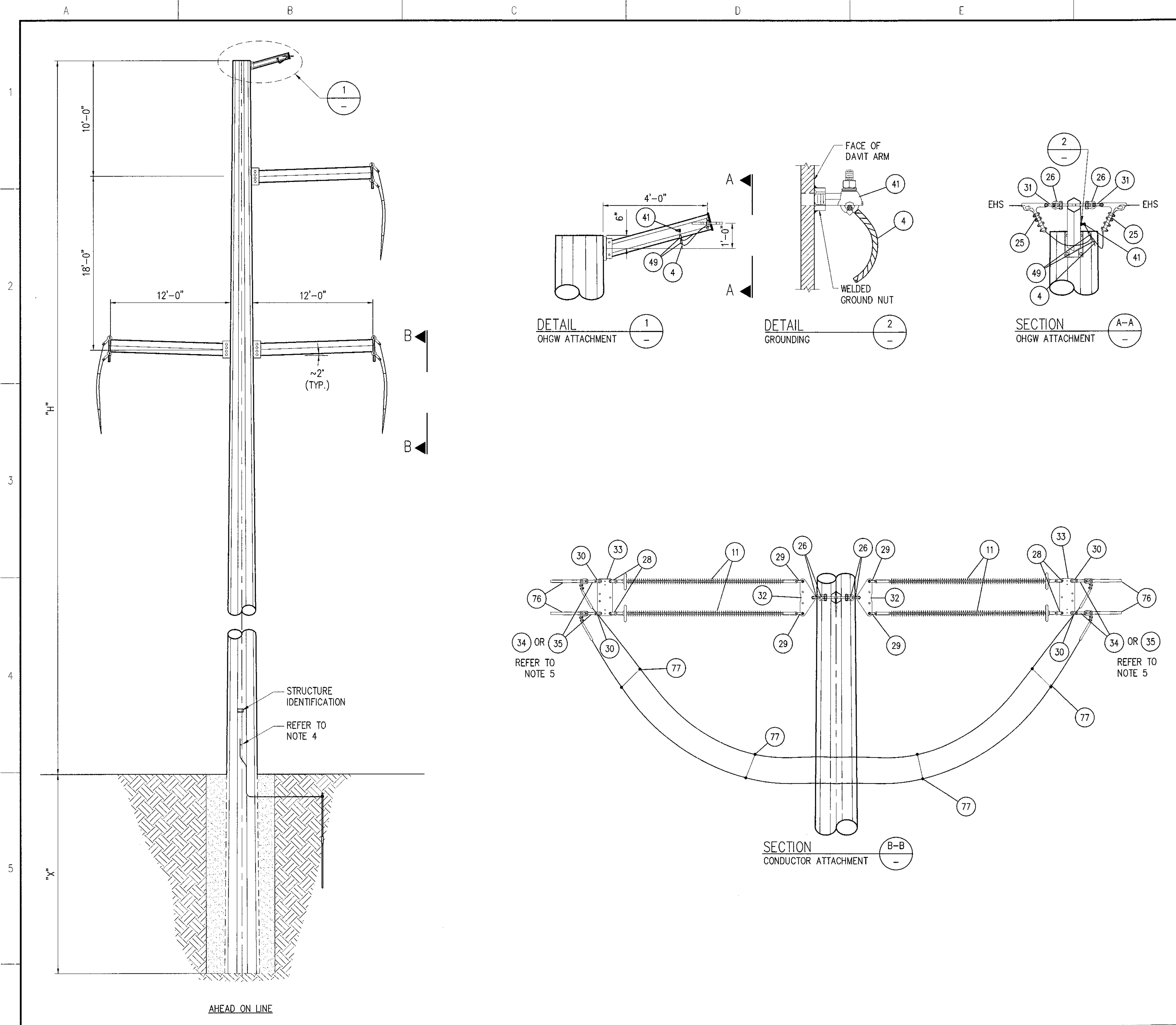

BILL OF MATERIAL		
ITEM NO.	QTY./STR.	
4	A/R	GROUND WIRE, #2 COPPER, 7-STRAND, BARE, IN FEET
11	12	INSULATOR ASSEMBLY, 230 kV, COMPOSITE, DEADEND, 50 KIP, MACLEAN #S27080088VASS031
25	2	QUADRANT STRAIN CLAMP, D.I., FOR 1/2" 7-STRAND EHS, HUBBELL #SWDE84N OR EQUAL
26	14	ANCHOR SHACKLE, 60 KIP, MACLEAN #ASH-67-BC OR EQUAL
28	12	SOCKET CLEVIS, 50 KIP, HUBBELL #SC501 OR EQUAL
29	12	BALL Y-CLEVIS, 50 KIP, MACLEAN #YCB-78 OR EQUAL
30	12	Y-CLEVIS CLEVIS, 40 KIP, MACLEAN #YCC-76 OR EQUAL
31	2	Y-CLEVIS EYE, 25 KIP, HUBBELL #YCS06 OR EQUAL
32	6	YOKE PLATE, DOUBLE BUNDLE, 2 TO 1, DEADEND, 60 KIP, MACLEAN #Y2DT060S1800 OR EQUAL
33	6	YOKE PLATE, DOUBLE BUNDLE, 2 TO 2, DEADEND, 60 KIP, MACLEAN #Y2DR060S1800 OR EQUAL
34	6	CLEVIS-EYE, RIGHT ANGLE, 45 KIP, MACLEAN #CEA-68-1125R OR EQUAL
35	6	CLEVIS-EYE, LEFT ANGLE, 45 KIP, MACLEAN #CEA-68-125L OR EQUAL
41	1	TANK GROUND, BRONZE, 1/2"-13 UNC STUD, #8 SOL. - 2/0 STR., MACLEAN #TG-820 OR EQUAL
49	2	GROUND BOND, MAIN 0.25"-0.56", TAP 0.16"-0.3", MACLEAN #BC-63 OR EQUAL
76	12	COMPRESSION DEADEND, SINGLE TONGUE WITH JUMPER, WITH SS HARDWARE, FOR 1272 KCM 45/7 ACSR "BITTERN", ANDERSON #A0315591SS OR EQUAL
77	12	CONDUCTOR SPACER, AFL #3319 OR EQUAL

STRUCTURE TABLE				
STRUCTURE NUMBER	STRUCTURE HEIGHT (FT)	EMBED LENGTH "X" (FT)	ABOVE GROUND HEIGHT "H" (FT)	QUANTITY
47B, 50B	90	20	70	2

- NOTES:
- TRANSMISSION LINE STRUCTURES DESIGNED IN ACCORDANCE WITH APPLIC'S SUGGESTED PRACTICES FOR AVIAN PROTECTION ON POWER LINES AND MIGRATING BIRD COLLISIONS WITH POWER LINES (2006).
  - REFER TO DRAWING BSEP-D-F008-SH1 FOR FOUNDATION DETAILS.
  - REFER TO DRAWING SET BSEP-B-T007 FOR STRUCTURAL LOADING INFORMATION.
  - REFER TO DRAWING BSEP-D-T003-SH10 FOR GROUNDING INSTALLATION DETAILS.
  - ANGLED CLEVIS EYE (ITEM NO. 34 OR 35) SHALL BE SELECTED SUCH THAT CONDUCTOR JUMPER ANGLES DOWN AND AWAY FROM POLE.
  - LOWEST SUBCONDUCTOR OF EACH JUMPER SHALL SAG 8 FEET (+0 FT/-1 FT) BELOW CONDUCTOR ATTACHMENT POINT.



**AS BUILT**  
01/18/16

Engineering with Distinction  
**ECI** ELECTRICAL CONSULTANTS, INC.  
 BILLINGS MONTANA

NO.	REVISION	DATE	BY	APP.
1	AS BUILT	18Jan2016	GS	
0	ISSUED FOR CONSTRUCTION	02Feb2015	GS	

**NEXTERA ENERGY**  
 AN FPL GROUP COMPANY  
 RESOURCES

ENGINEERING RECORD		DATE
DRAWN	DJW	18Jan2016
DESIGNED	MRF	18Jan2016
CHECKED	BMS	18Jan2016
APPROVED	GS	18Jan2016
DWG SCALE:		PLT SCALE:

COLORADO RIVER - DRACKER  
 230 kV TRANSMISSION LINE PROJECT  
 SGL. CIR. STEEL DELTA FALSE DEADEND STR.

DWG. NAME: BSEP-D-T003-SH3 REVISION NO.: 1

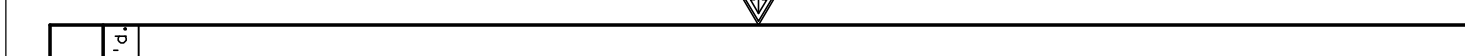

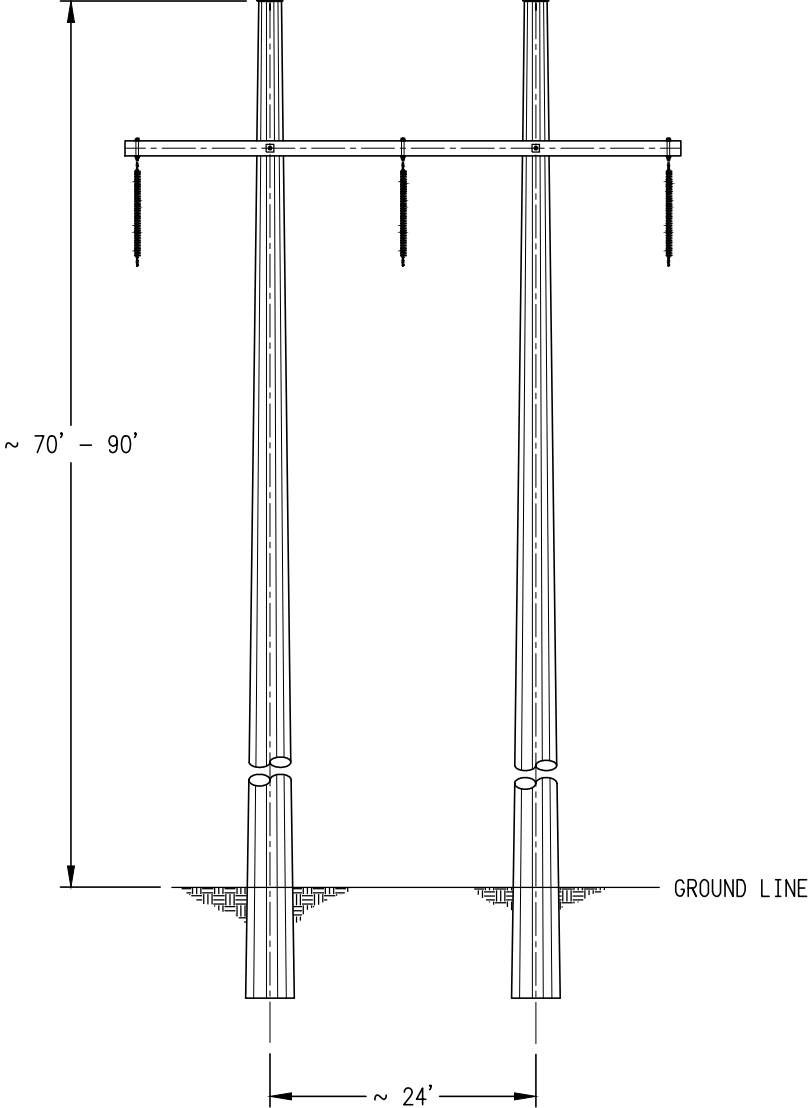
**FOR CONCEPTUAL USE ONLY**

Location: NEXTERA MCCOY SOLAR ENERGY PROJECT			
230 kV 1CKT H-FRAME			
PROPOSED TANGENT STRUCTURE			
No.	Revisions	Made P.E.	D/L
M-0004-A			1

\* REVISE ON AUTOCAD SYSTEM ONLY \*

